

2 - Loading table

CODE	DESCRIPTION
130410	STOP CONTACT F40 CN RED
130411	START CONTACT YELLOW
130413	GREEN PUSH BUTTON
130466	EMERGENCY SWITCH
160831	WASHER F2 17X6X3
161135	PROTECTION FOR PUSH BUTTON NE
190918	CURTAIN IN/OUT NG-910X680
190919	MIDDLE CURTAIN NG-910X680
200432	SPONGY RUBBER ADHESIV 8X4 NEOP
210404	BLACK RUBBER FOOT S90 NE SE
260224	TB-SCREW 6X15 B23-10-11-12
260512	ST/ST GROWER WASHER D6
260538	WASHER 18X6X1,5 ST/ST
290701	HEXAGON BLIND NUTS GM H12
290827	SPACER NG-LVP1001
320992	DOOR
330418	HOOD
330419	HOOD
330715	UPPER BRACKET CURTAIN SNL-SE
331035	HANDLE NE/G125L
340614	ENTRY TABLE COVER
341273	LEVER
341276	SPINDLE FOR CURTAIN NG
351218	PANEL
351229	FRONT PANEL CA/CH 225
351500	PANEL 200 NE
351503	BACK PANEL
351590	PANEL
391243	FRAME
391244	FRAME
461094	CONTROL PANEL
461139	PLATE
620222	COMPLETE ALUMINIUM LEGS

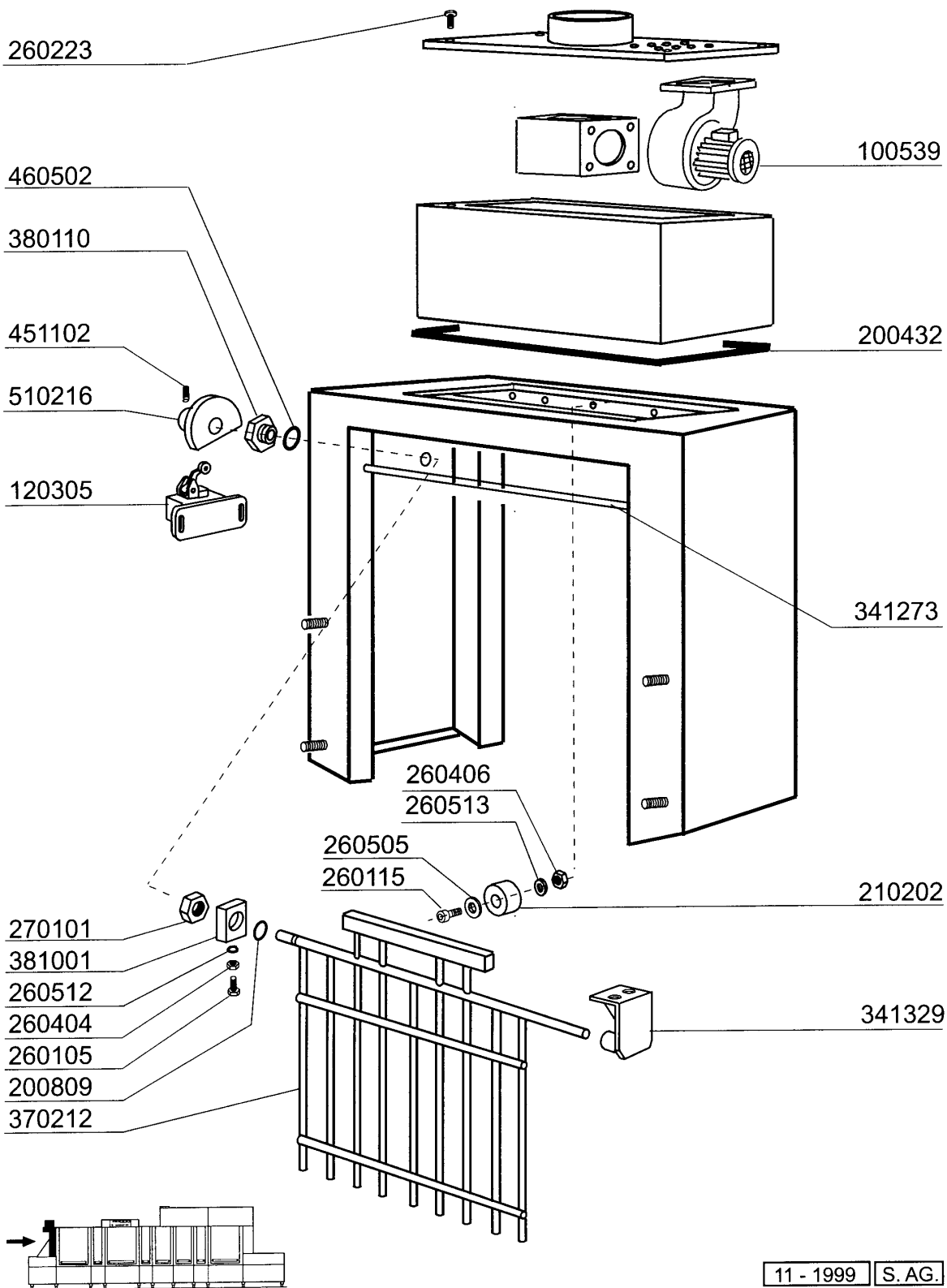

3 - Vent Hood

CODE	DESCRIPTION
100539	EXHAUST FAN F.SPLASH GUARD 220
120305	MICRO SWITCH WITH LEVER
200432	SPONGY RUBBER ADHESIV 8X4 NEOP
200809	OR GASKET 1,78X8,73X12,29
210202	RUBBER FOOT GLASSWASHER
260105	SCREW TE 6X20
260115	STAIN.ST.TE SCREW 8X20 A2 UNI
260223	M5X12 MSH/HD SCREW SPECIAL S/S
260404	STAINLESS STEEL NUTS D6 UNI 55
260406	NUT 8MA
260505	STAINL.STEEL FLAT WASHER D8
260512	ST/ST GROWER WASHER D6
260513	GROWER WASHER D8
270101	HEXAGON LOCK NUT 1/2"
341273	LEVER
341329	SUPPORT (341846)
370212	RINSE ECONOMISER GATE NG
380110	BRASS BEARING D12 F.ECON.N
381001	LOCKING NUT FOR ECONOMIZER N
451102	RINSE GATE PIN 3X26
460502	GASKET 30X21X2
510216	N RINSE GATE ECCENTRE

4 - 1st Wash Hood 1000mm

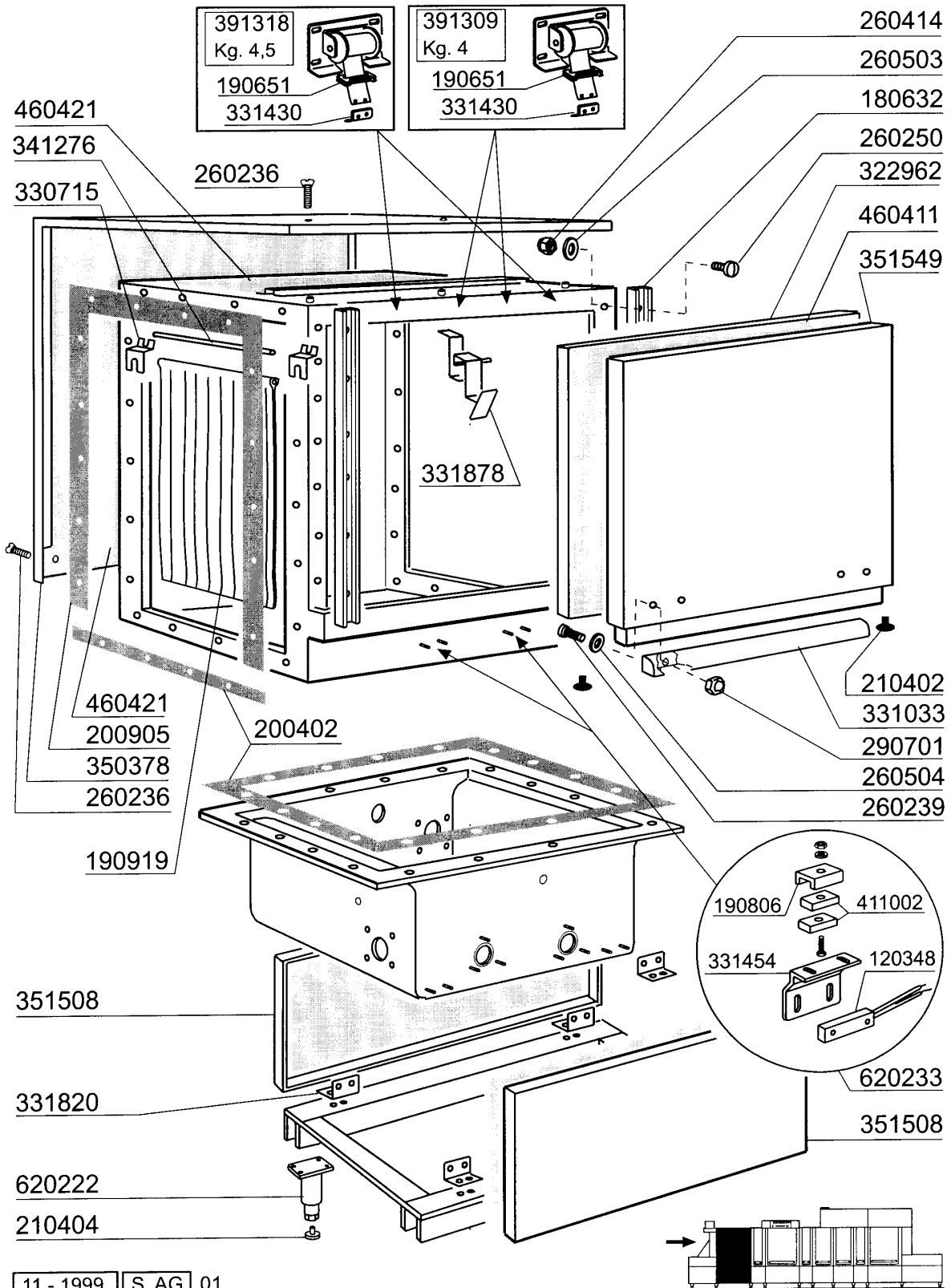

11 - 1999 | S. AG. | 01

4 - 1st Wash Hood 1000mm

CODE	DESCRIPTION
120348	MAGN.SWITCH (N.O.)
180632	GUIDE
190651	BUSH
190806	MAGNET HOUSING
190919	MIDDLE CURTAIN NG-910X680
200402	SELF-ADHES.RUBB.SPONGE STRIPS
200905	SELFADHESIVE GASKET 4X35
210402	PAD FOR DOOR 15-149
210404	BLACK RUBBER FOOT S90 NE SE
260236	SCREW TCP 3X35
260239	SPECIAL S/S TB-SCREWS M6X20
260250	SCREW TB 5X20
260414	SELF-LOCKING NUT M5
260503	STAINL.STEEL FLAT WASHER D5 UN
260504	ST/ST FLAT WASHER D6
290701	HEXAGON BLIND NUTS GM H12
322962	DOOR 1000
330715	UPPER BRACKET CURTAIN SNL-SE
331033	1000MM DOOR HANDLE NE D.SKINNE
331430	BRACKET FOR DOOR SPRING
331454	MICRO SWITCH BRACKET
331820	BRACKET
331878	HOOK FOR DOOR SUPPORT NG
341276	SPINDLE FOR CURTAIN NG
350378	INSULATED PANEL 1000MM
351508	FRONT/BACK PANEL 1000 NE
351549	PANEL
391309	DOOR SPRING 4KG - 40MM
391318	DOOR SPRING 4,5KG - 40MM
411002	PERMANENT MAGNET 24X12
460411	VIBROCELL
460421	ISOLATION
620222	COMPLETE ALUMINIUM LEGS
620233	DOOR MAGN.SWITCH G/NE/NG/LV

5 - 1st Wash Column

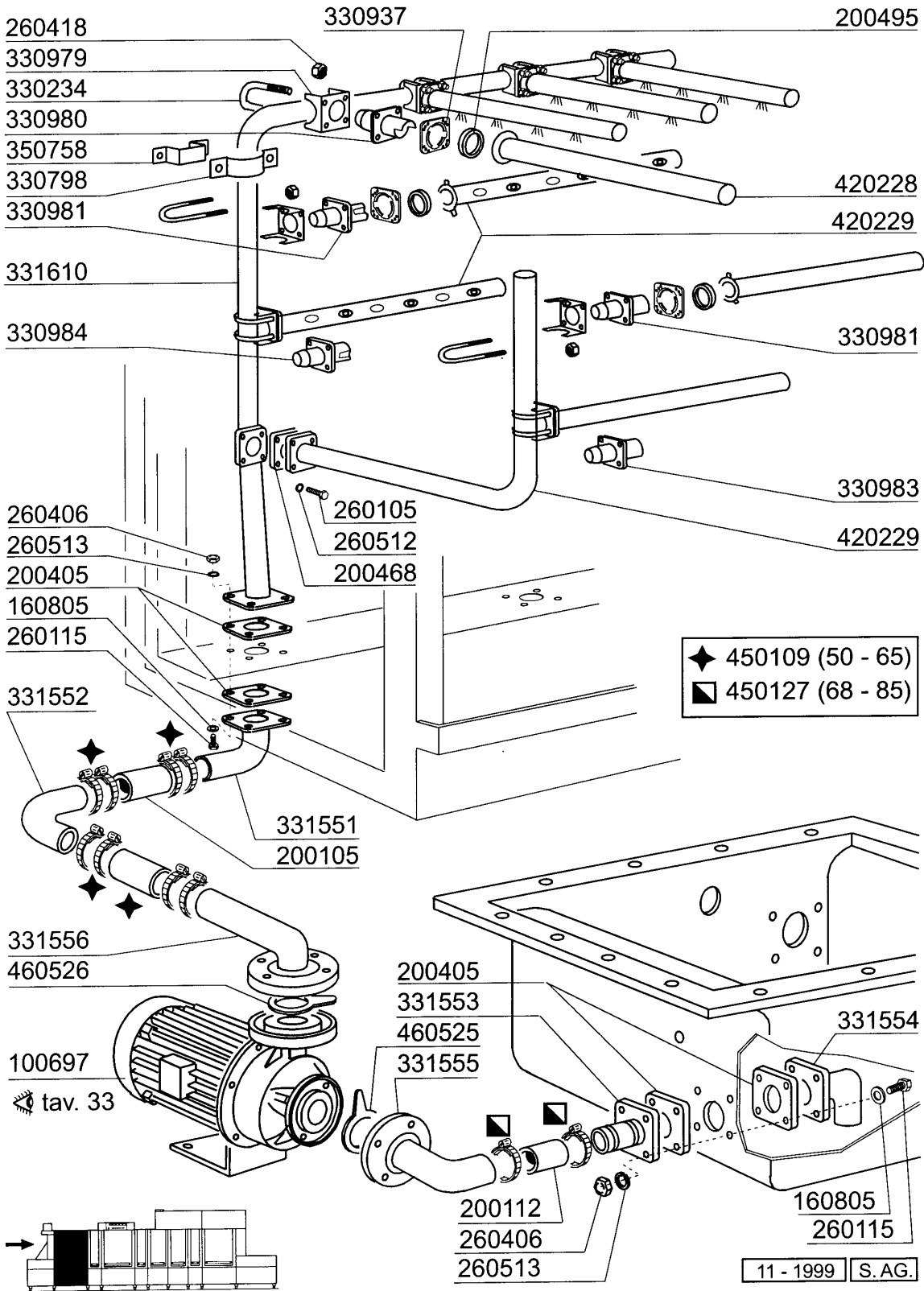

5 - 1st Wash Column

CODE	DESCRIPTION
100697	PUMP HP 4 230/400/50 SHE 50
160805	GASKET D.8
200105	RUBBER HOSE 50X60
200112	RUBBER TUBE 75X83
200405	GASKET 110X100X63 IN NEOTEN
200468	GASKET 70X70X3 NEOTEN NE
200495	GASKET FOR ACR S/S WASH ARM 43
260105	SCREW TE 6X20
260115	STAIN.ST.TE SCREW 8X20 A2 UNI
260406	NUT 8MA
260418	SELF-LOCKING NUT M4
260512	ST/ST GROWER WASHER D6
260513	GROWER WASHER D8
330234	TIE ROD
330798	BRACKET
330937	FLANGE
330979	FLANGE
330980	FLANGE CENTRAL FOR ARM NE-NG
330981	FIXING FOR ARM NE-NG
330983	FIXING
330984	FIXING
331551	ELBOW FOR WASH COLUMN NG-G75
331552	DELIVERY ELBOW FOR NG
331553	INLET ELBOW FOR NG-GL WASH PUM
331554	INLET ELBOW FOR NG PUMP
331555	INLET ELBOW FOR NG WASH PUMP
331556	DELIVERY ELBOW NG WASH
331610	WASH COLUMN
350758	BRACKET
420228	WASH ARM
420229	SIDE WASH ARM
450109	CLAMP 50-65
450127	CLAMP FE ZN. 68-85 H=12,2
460525	GASKET INLET ELBOW WASH PUMP
460526	GASKET DELIVERY ELBOW WASH P.

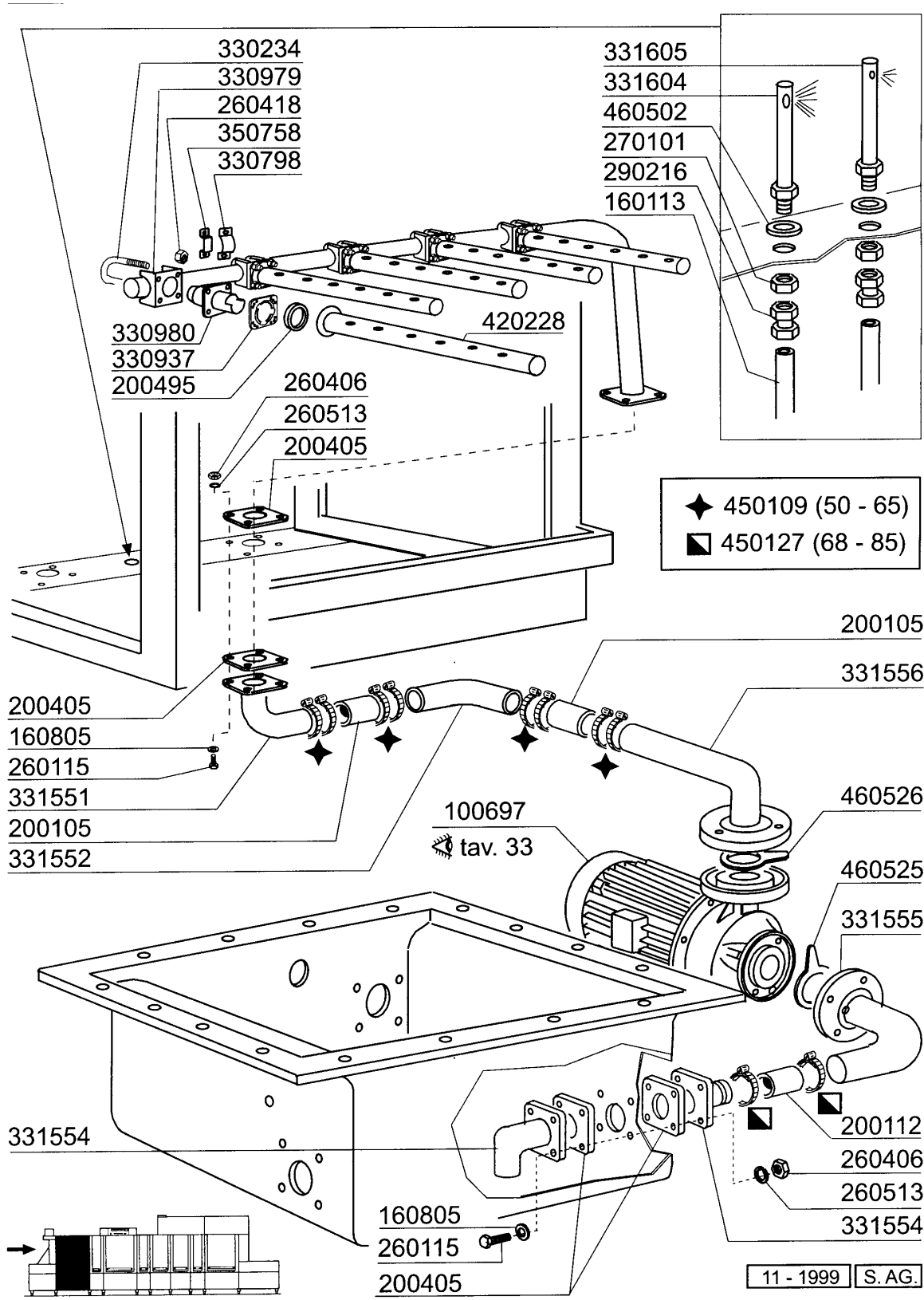

6 - 1st Wash Column

CODE	DESCRIPTION
100697	PUMP HP 4 230/400/50 SHE 50
160113	TUBE IN POL. RETIC. 12 EST
160805	GASKET D.8
200105	RUBBER HOSE 50X60
200112	RUBBER TUBE 75X83
200405	GASKET 110X100X63 IN NEOTEN
200495	GASKET FOR ACR S/S WASH ARM 43
260115	STAIN.ST.TE SCREW 8X20 A2 UNI
260406	NUT 8MA
260418	SELF-LOCKING NUT M4
260513	GROWER WASHER D8
270101	HEXAGON LOCK NUT 1/2"
290216	HOSE CLAMPS STRAIGHT 12X1/2"
330234	TIE ROD
330798	BRACKET
330937	FLANGE
330979	FLANGE
330980	FLANGE CENTRAL FOR ARM NE-NG
331551	ELBOW FOR WASH COLUMN NG-G75
331552	DELIVERY ELBOW FOR NG
331554	INLET ELBOW FOR NG PUMP
331555	INLET ELBOW FOR NG WASH PUMP
331556	DELIVERY ELBOW NG WASH
331604	TANK FILL HOSE
331605	ELBOW
350758	BRACKET
420228	WASH ARM
450109	CLAMP 50-65
450127	CLAMP FE ZN. 68-85 H=12,2
460502	GASKET 30X21X2
460525	GASKET INLET ELBOW WASH PUMP
460526	GASKET DELIVERY ELBOW WASH P.

450127 (68 - 85)

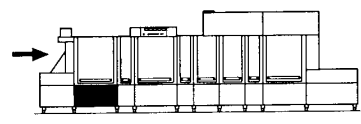
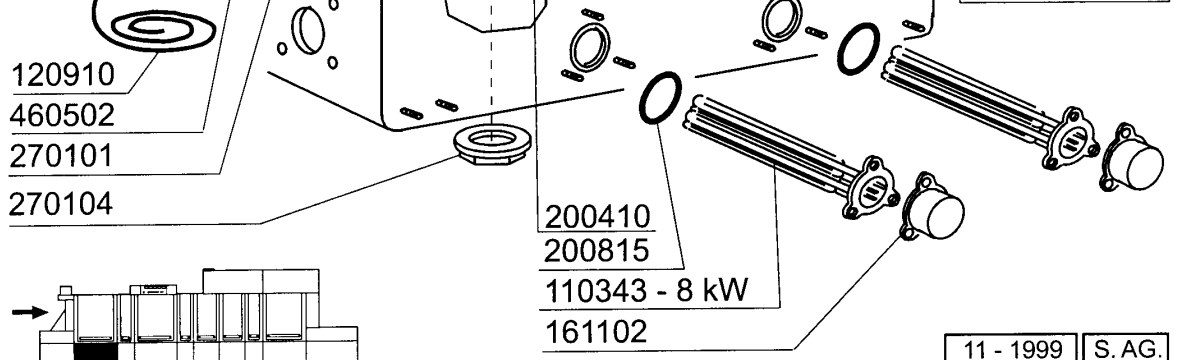
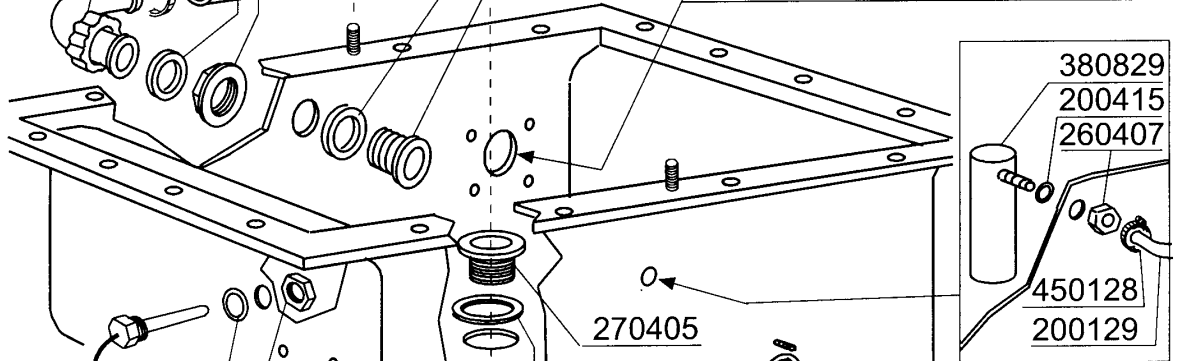
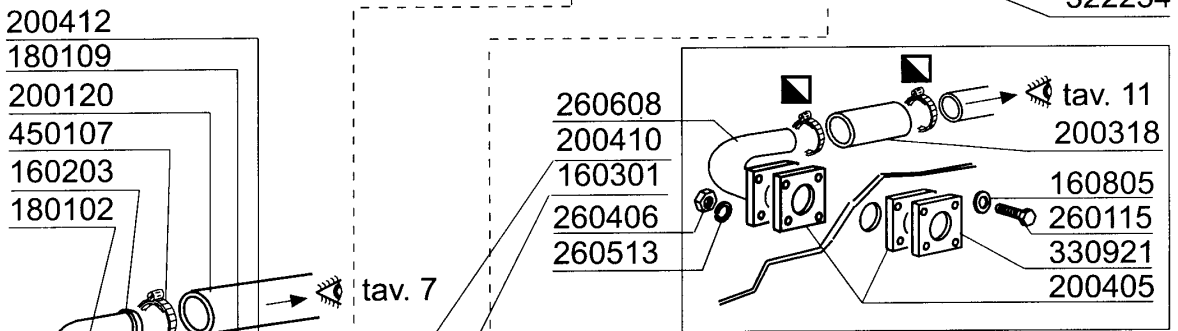
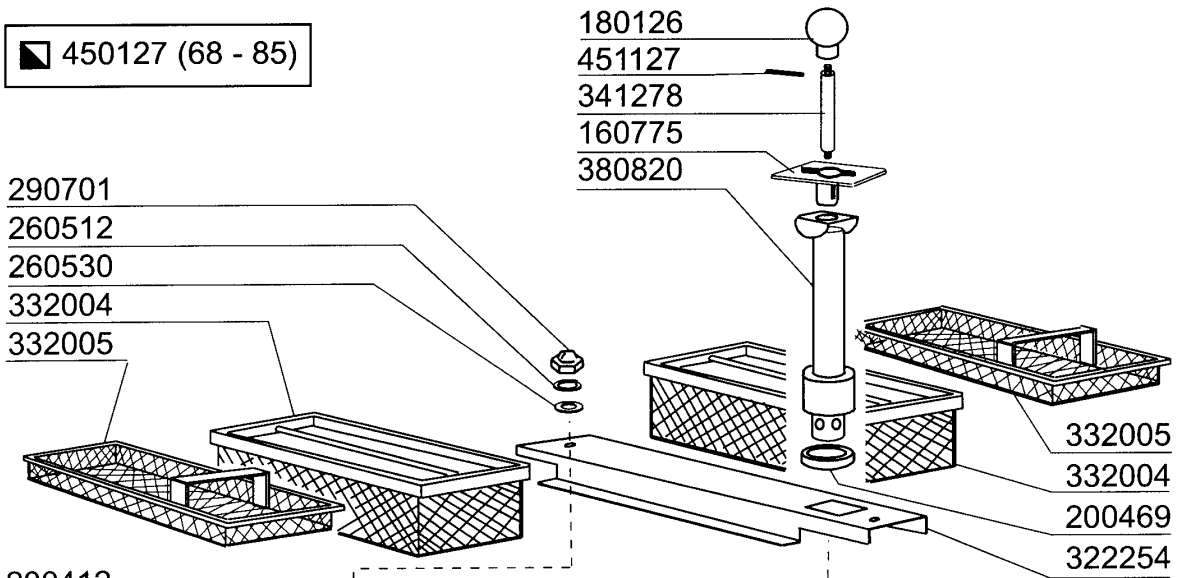

11 - 1999 | S. AG.

7 - 1st Wash Tank 1000mm

CODE	DESCRIPTION
110343	HEAT.ELEM. 8000W 220/380V
120910	ELECTRONIC TOUCH PAD CONTROLS
160203	ELBOW 1"1/2 N-S-F-C /DRAIN
160301	DRAIN OUTLET 1"1/2 C-S-N
160775	OVERFLOW PIPE PLUG PREWASH NG
160805	GASKET D.8
161102	ELEMENT COVER MOPL.
180102	DRAIN PIPE NUT 1"1/2 F45-55
180109	LOCK NUT 1 1/2"
180126	HANDLE F.OVERFLOW PIPE SNL
200120	RUBBER HOSE 35X48
200129	HOSE 5X11 FOR PRESSURE SWITCH
200318	INLET HOSE 64X76 C34 SE
200405	GASKET 110X100X63 IN NEOTEN
200410	DRAIN OUTL.WASH.1 1/2"65X47X2
200412	GASKET DRAIN 11/2" 45X33X3
200415	AIR TRAP GASKET -F2 18,5X10X3
200469	STAND PIPE O RING 45X35,5X7
200815	O-RING F. HEAT.ELEM.
260115	STAIN.ST.TE SCREW 8X20 A2 UNI
260406	NUT 8MA
260407	STAINLESS STEEL NUTS D10 UNI 5
260512	ST/ST GROWER WASHER D6
260513	GROWER WASHER D8
260530	STAINL.ST WASHER 7X22X2
260608	CONNECTION0
270101	HEXAGON LOCK NUT 1/2"
270104	LOCK NUT 1" 1/2
270405	DRAIN OUTLET N
290701	HEXAGON BLIND NUTS GM H12
322254	SUPPORT FOR FILTERS
330921	FLANGE 100X100X61-110
332004	PREWASH FILTER NE XL
332005	WASH FILTER NE XL
341278	SPACER FOR NG OVERFLOW
380820	OVERFLOW PIPE/1ØWASH. TANK NG9
380829	ST/ST AIR CHAMBER FOR NG-NE
450107	CLAMP FE ZN 38-50 H=12,2
450127	CLAMP FE ZN. 68-85 H=12,2
450128	CLAMP
451127	ELASTIC PIN 5X34
460502	GASKET 30X21X2

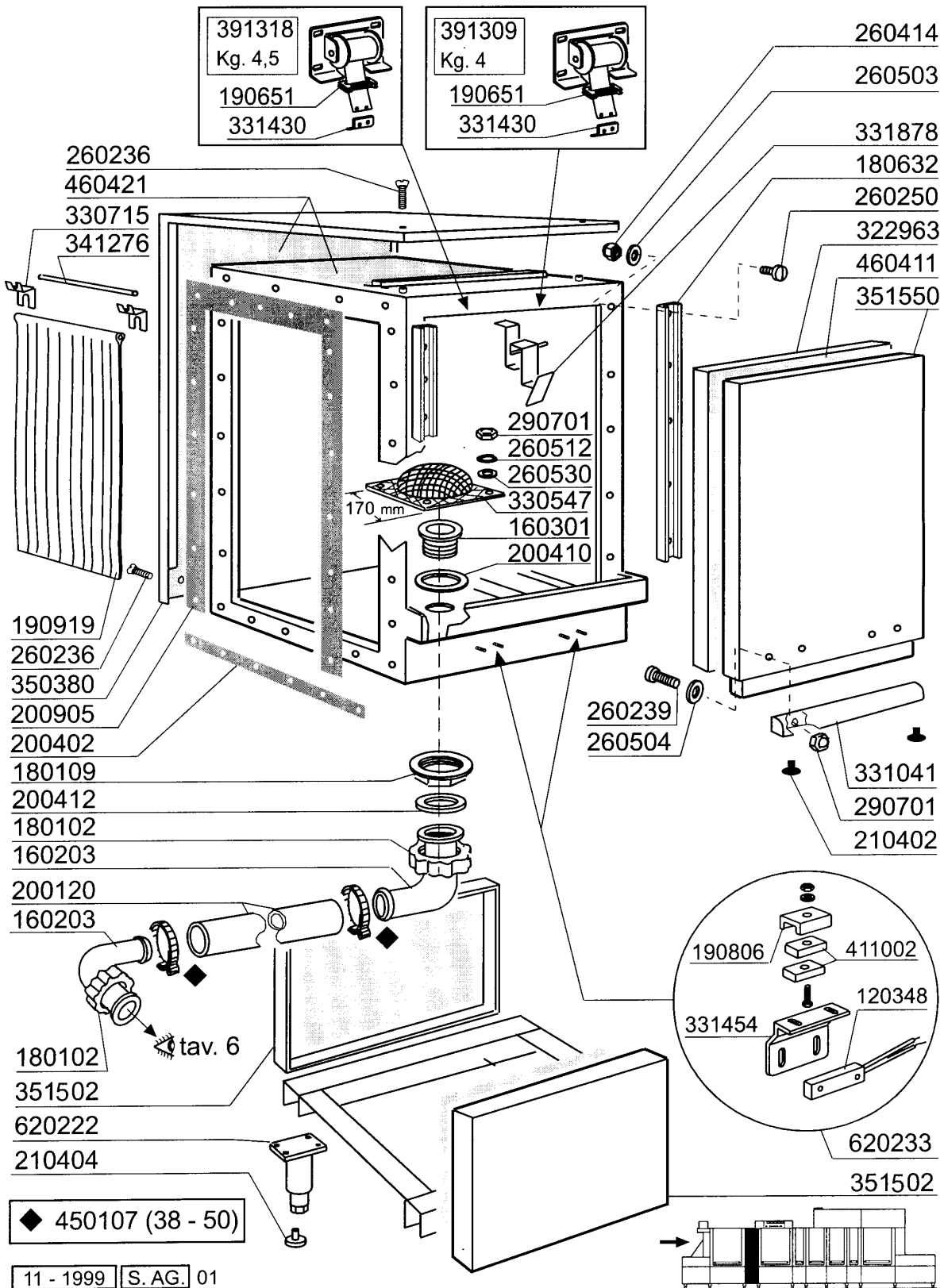

8 - Neutral zone 400mm

CODE	DESCRIPTION
120348	MAGN.SWITCH (N.O.)
160203	ELBOW 1"1/2 N-S-F-C /DRAIN
160301	DRAIN OUTLET 1"1/2 C-S-N
180102	DRAIN PIPE NUT 1"1/2 F45-55
180109	LOCK NUT 1 1/2"
180632	GUIDE
190651	BUSH
190806	MAGNET HOUSING
190919	MIDDLE CURTAIN NG-910X680
200120	RUBBER HOSE 35X48
200402	SELF-ADHES.RUBB.SPONGE STRIPS
200410	DRAIN OUTL.WASH.1 1/2"65X47X2
200412	GASKET DRAIN 11/2" 45X33X3
200905	SELFADHESIVE GASKET 4X35
210402	PAD FOR DOOR 15-149
210404	BLACK RUBBER FOOT S90 NE SE
260236	SCREW TCP 3X35
260239	SPECIAL S/S TB-SCREWS M6X20
260250	SCREW TB 5X20
260414	SELF-LOCKING NUT M5
260503	STAINL.STEEL FLAT WASHER D5 UN
260504	ST/ST FLAT WASHER D6
260512	ST/ST GROWER WASHER D6
260530	STAINL.ST WASHER 7X22X2
290701	HEXAGON BLIND NUTS GM H12
322963	DOOR 400
330547	FILTER F.TANK DRAIN NE/NG BTM
330715	UPPER BRACKET CURTAIN SNL-SE
331041	400MM DOOR HANDLE ACR/NE D.SKI
331430	BRACKET FOR DOOR SPRING
331454	MICRO SWITCH BRACKET
331878	HOOK FOR DOOR SUPPORT NG
341276	SPINDLE FOR CURTAIN NG
350380	INSULATED PANEL 400MM
351502	PANEL
351550	PANEL
391309	DOOR SPRING 4KG - 40MM
391318	DOOR SPRING 4,5KG - 40MM
411002	PERMANENT MAGNET 24X12
450107	CLAMP FE ZN 38-50 H=12,2
460411	VIBROCELL
460421	ISOLATION
620222	COMPLETE ALUMINIUM LEGS
620233	DOOR MAGN.SWITCH G/NE/NG/LV

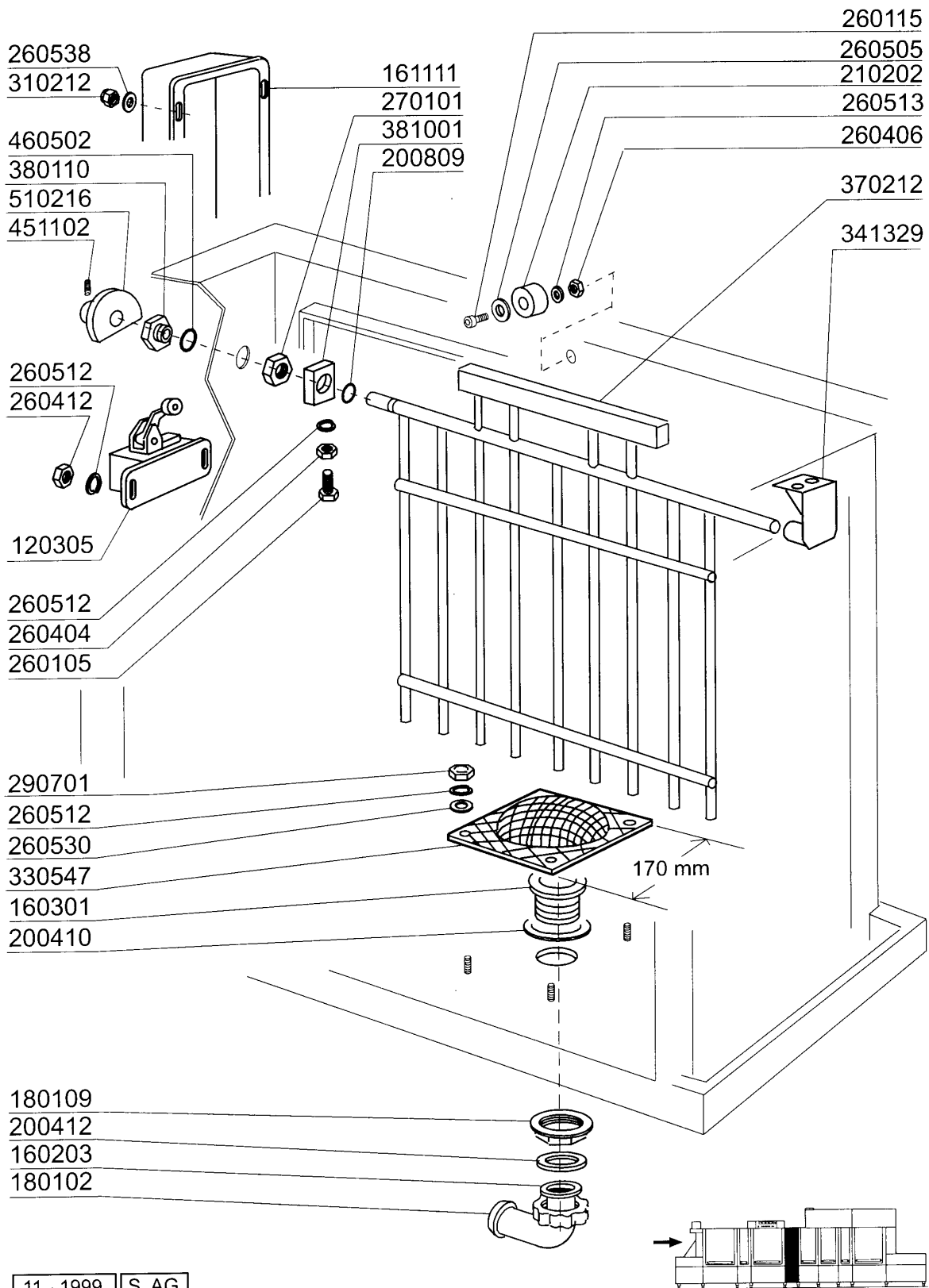

11 - 1999 S. AG.

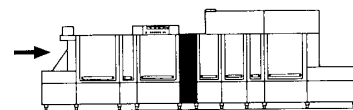

9 - Economiser

CODE	DESCRIPTION
120305	MICRO SWITCH WITH LEVER
160203	ELBOW 1"1/2 N-S-F-C /DRAIN
160301	DRAIN OUTLET 1"1/2 C-S-N
161111	BACK COVER CHANNEL 130 N S2900
180102	DRAIN PIPE NUT 1"1/2 F45-55
180109	LOCK NUT 1 1/2"
200410	DRAIN OUTL.WASH.1 1/2"65X47X2
200412	GASKET DRAIN 11/2" 45X33X3
200809	OR GASKET 1,78X8,73X12,29
210202	RUBBER FOOT GLASSWASHER
260105	SCREW TE 6X20
260115	STAIN.ST.TE SCREW 8X20 A2 UNI
260404	STAINLESS STEEL NUTS D6 UNI 55
260406	NUT 8MA
260412	SELF-LOCKING NUT M6
260505	STAINL.STEEL FLAT WASHER D8
260512	ST/ST GROWER WASHER D6
260513	GROWER WASHER D8
260530	STAINL.ST WASHER 7X22X2
260538	WASHER 18X6X1,5 ST/ST
270101	HEXAGON LOCK NUT 1/2"
290701	HEXAGON BLIND NUTS GM H12
310212	BLIND NUT M6 BLACK NYLON
330547	FILTER F.TANK DRAIN NE/NG BTM
341329	SUPPORT (341846)
370212	RINSE ECONOMISER GATE NG
380110	BRASS BEARING D12 F.ECON.N
381001	LOCKING NUT FOR ECONOMIZER N
451102	RINSE GATE PIN 3X26
460502	GASKET 30X21X2
510216	N RINSE GATE ECCENTRE

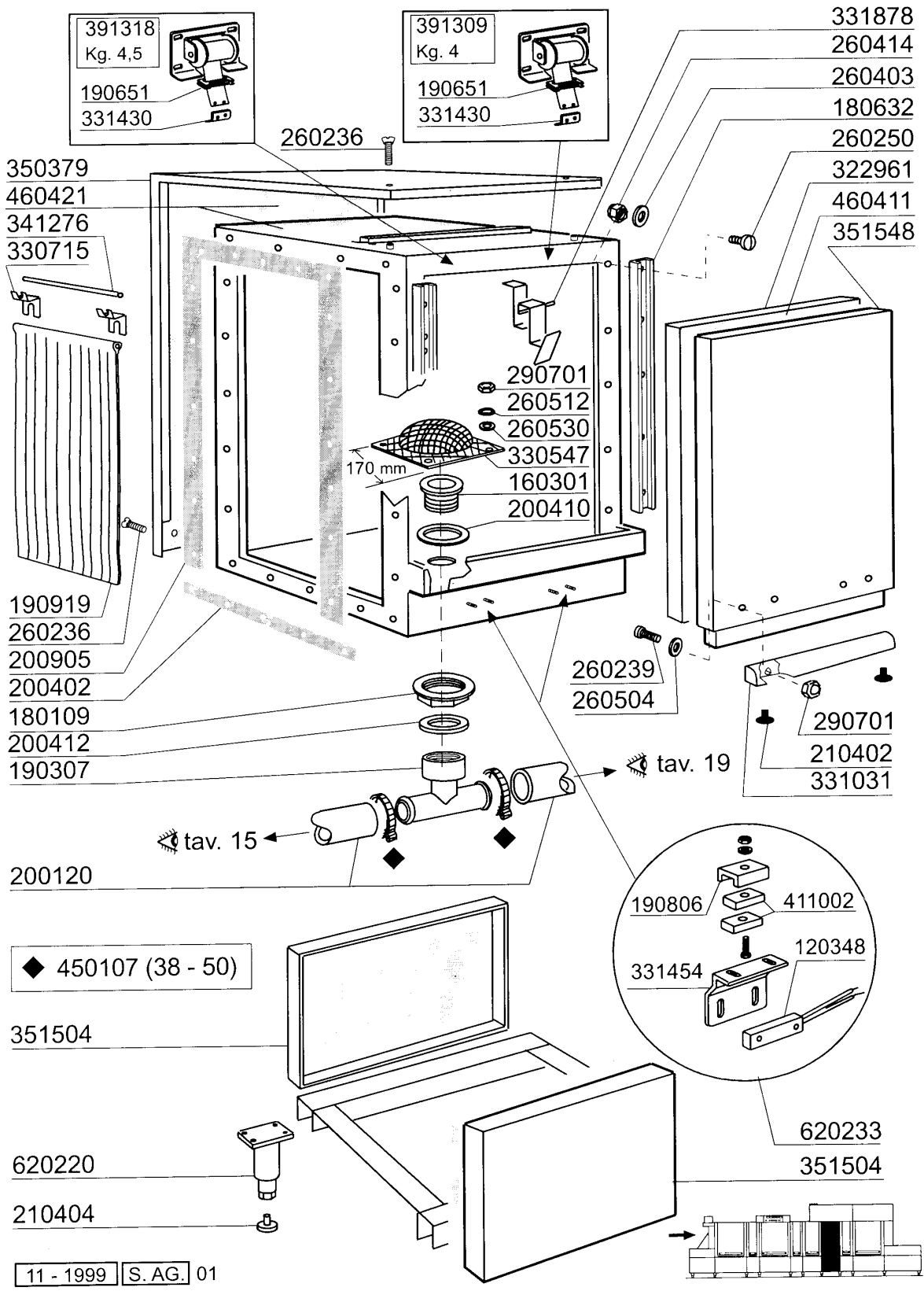

10 - Rinse Hood 600mm

CODE	DESCRIPTION
120348	MAGN.SWITCH (N.O.)
160301	DRAIN OUTLET 1"1/2 C-S-N
180109	LOCK NUT 1 1/2"
180632	GUIDE
190307	SPECIAL TEE GRAU MPL.
190651	BUSH
190806	MAGNET HOUSING
190919	MIDDLE CURTAIN NG-910X680
200120	RUBBER HOSE 35X48
200402	SELF-ADHES.RUBB.SPONGE STRIPS
200410	DRAIN OUTL.WASH.1 1/2"65X47X2
200412	GASKET DRAIN 11/2" 45X33X3
200905	SELFADHESIVE GASKET 4X35
210402	PAD FOR DOOR 15-149
210404	BLACK RUBBER FOOT S90 NE SE
260236	SCREW TCP 3X35
260239	SPECIAL S/S TB-SCREWS M6X20
260250	SCREW TB 5X20
260403	NUTS D.5
260414	SELF-LOCKING NUT M5
260504	ST/ST FLAT WASHER D6
260512	ST/ST GROWER WASHER D6
260530	STAINL.ST WASHER 7X22X2
290701	HEXAGON BLIND NUTS GM H12
322961	DOOR 600
330547	FILTER F.TANK DRAIN NE/NG BTM
330715	UPPER BRACKET CURTAIN SNL-SE
331031	600MM DOOR HANDLE ACR/NE D.SKI
331430	BRACKET FOR DOOR SPRING
331454	MICRO SWITCH BRACKET
331878	HOOK FOR DOOR SUPPORT NG
341276	SPINDLE FOR CURTAIN NG
350379	INSULATED PANEL
351504	PANEL 600 NE
351548	PANEL
391309	DOOR SPRING 4KG - 40MM
391318	DOOR SPRING 4,5KG - 40MM
411002	PERMANENT MAGNET 24X12
450107	CLAMP FE ZN 38-50 H=12,2
460411	VIBROCELL
460421	ISOLATION
620220	.
620233	DOOR MAGN.SWITCH G/NE/NG/LV

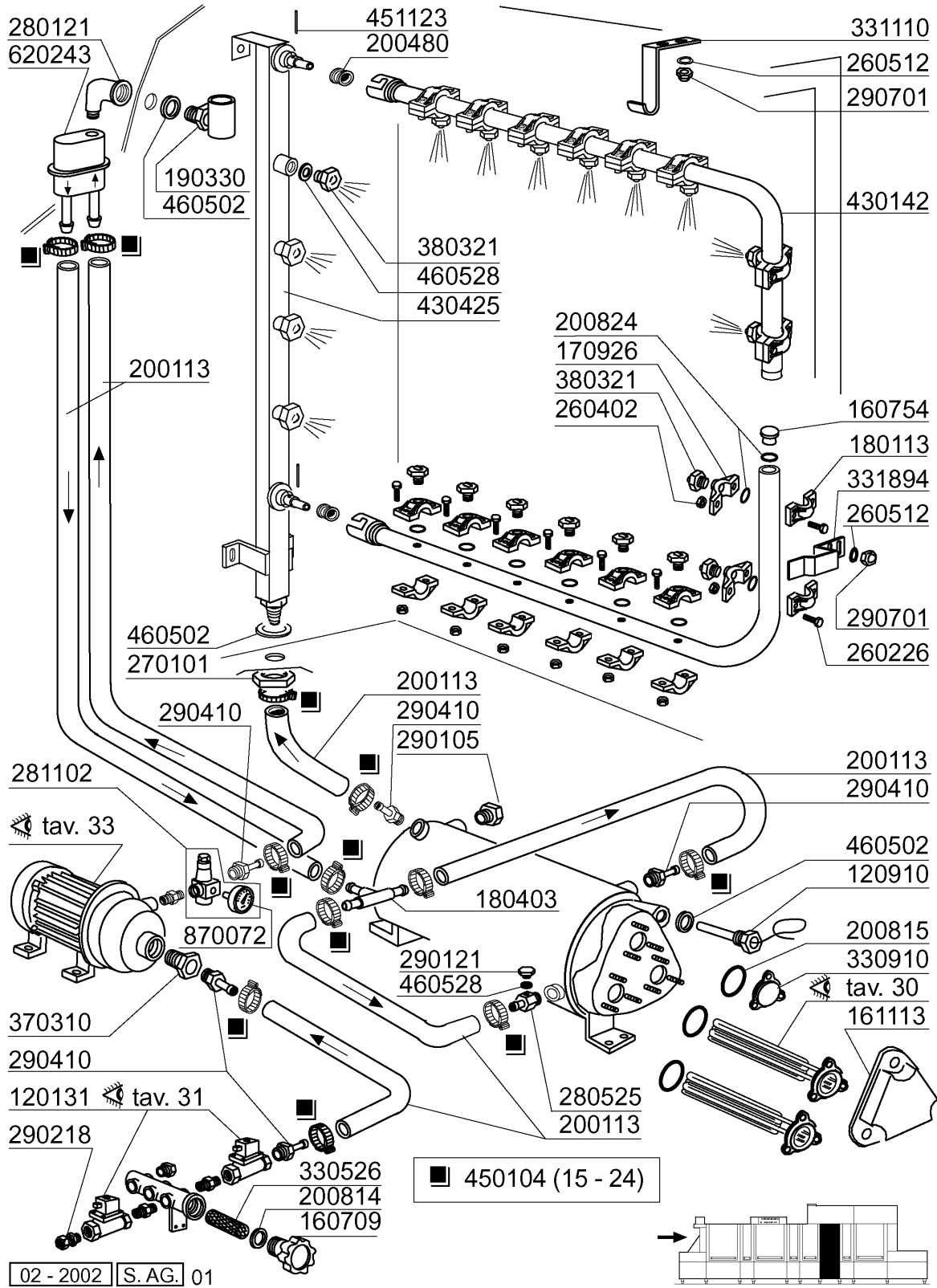

11 - Rinse assembly

CODE	DESCRIPTION
120131	SOLEN. L182Q31-ZB10A 1/2"24V
120910	ELECTRONIC TOUCH PAD CONTROLS
160709	KNOB OF MANIFOLD F. SOLEN. VAL
160754	PLUG FOR RINSE ARMS SE NE
161113	ELEMENT COVER BLACK
170926	RINSE JET HOLDER S-SE-NE
180113	NUT
180403	TEE-NIPPLE F2-F300-B10-11
190330	TEE FOR VAACUM BREAKER
200113	RUBBER HOSE 12 X 22
200480	GASKET F. RINSE CONNECT.
200814	O-RING 34,52X41,58X3,53
200815	O-RING F. HEAT.ELEM.
200824	O-RING 1,78X12,42X15,98
260226	STAINL.ST TCP SCREW 4X12 A2 UN
260402	STAINLESS STEEL NUT D4 UNI 55
260512	ST/ST GROWER WASHER D6
270101	HEXAGON LOCK NUT 1/2"
280121	ELL FOR VAACUM BREAKER
280525	NIPPLE
281102	1/2" ADJ VALVE C/W GAUGE TYPE
290105	BRASS-TE-PLUG 1/2"
290121	BRASS PLUG 1/8"
290218	NIPPLE 12X1/2"
290410	NIPPLE 1/2"
290701	HEXAGON BLIND NUTS GM H12
330526	FILTERS 22X28 SOLENOID V.MANIF
330910	FLANGE
331110	SUPPORT.HOOK F.UPPER RINSE ARM
331894	BRACKET
370310	CONVEYOR END RUN ARM NEXL
380321	RINSE JETS OV 1/8" 303 40LT 80
430142	NG RINSE ARM
430425	RINSE COLUMN
450104	CLAMP FE ZN H=12,5 15-24
451123	ELASTIC PIN 4X16
460502	GASKET 30X21X2
460528	GASKET 15X10X2 FOR RINSE NIPPE
620243	VACUUM BREAKER (WITHOUT KIT)
870072	PRESSURE CAUGE 0-4 ATM

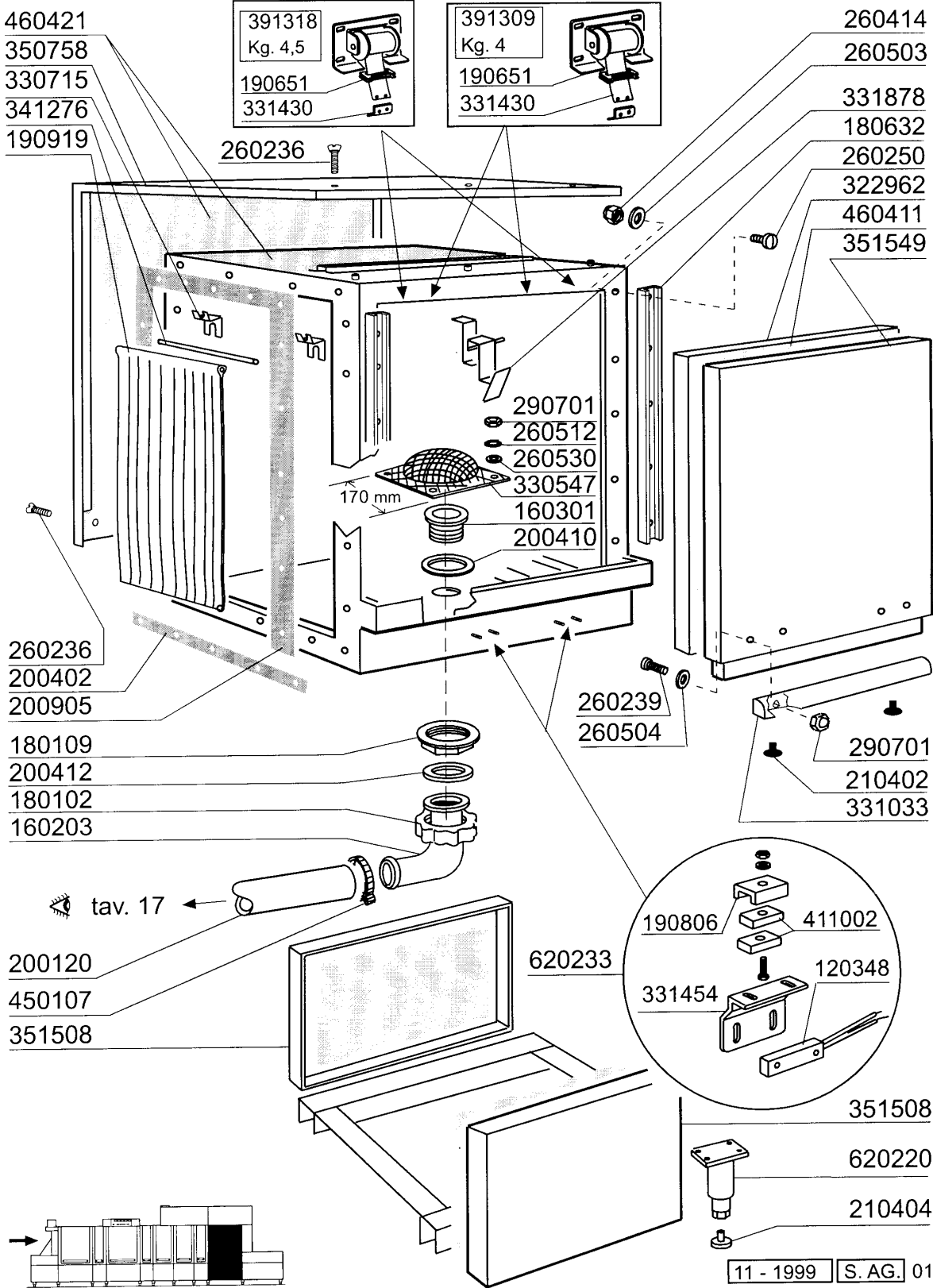

12 - Dryer hood 1000mm

CODE	DESCRIPTION
120348	MAGN.SWITCH (N.O.)
160203	ELBOW 1"1/2 N-S-F-C /DRAIN
160301	DRAIN OUTLET 1"1/2 C-S-N
180102	DRAIN PIPE NUT 1"1/2 F45-55
180109	LOCK NUT 1 1/2"
180632	GUIDE
190651	BUSH
190806	MAGNET HOUSING
190919	MIDDLE CURTAIN NG-910X680
200120	RUBBER HOSE 35X48
200402	SELF-ADHES.RUBB.SPONGE STRIPS
200410	DRAIN OUTL.WASH.1 1/2"65X47X2
200412	GASKET DRAIN 11/2" 45X33X3
200905	SELFADHESIVE GASKET 4X35
210402	PAD FOR DOOR 15-149
210404	BLACK RUBBER FOOT S90 NE SE
260236	SCREW TCP 3X35
260239	SPECIAL S/S TB-SCREWS M6X20
260250	SCREW TB 5X20
260414	SELF-LOCKING NUT M5
260503	STAINL.STEEL FLAT WASHER D5 UN
260504	ST/ST FLAT WASHER D6
260512	ST/ST GROWER WASHER D6
260530	STAINL.ST WASHER 7X22X2
290701	HEXAGON BLIND NUTS GM H12
322962	DOOR 1000
330547	FILTER F.TANK DRAIN NE/NG BTM
330715	UPPER BRACKET CURTAIN SNL-SE
331033	1000MM DOOR HANDLE NE D.SKINNE
331430	BRACKET FOR DOOR SPRING
331454	MICRO SWITCH BRACKET
331878	HOOK FOR DOOR SUPPORT NG
341276	SPINDLE FOR CURTAIN NG
350758	BRACKET
351508	FRONT/BACK PANEL 1000 NE
351549	PANEL
391309	DOOR SPRING 4KG - 40MM
391318	DOOR SPRING 4,5KG - 40MM
411002	PERMANENT MAGNET 24X12
450107	CLAMP FE ZN 38-50 H=12,2
460411	VIBROCELL
460421	ISOLATION
620220	.
620233	DOOR MAGN.SWITCH G/NE/NG/LV

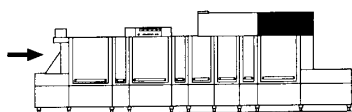
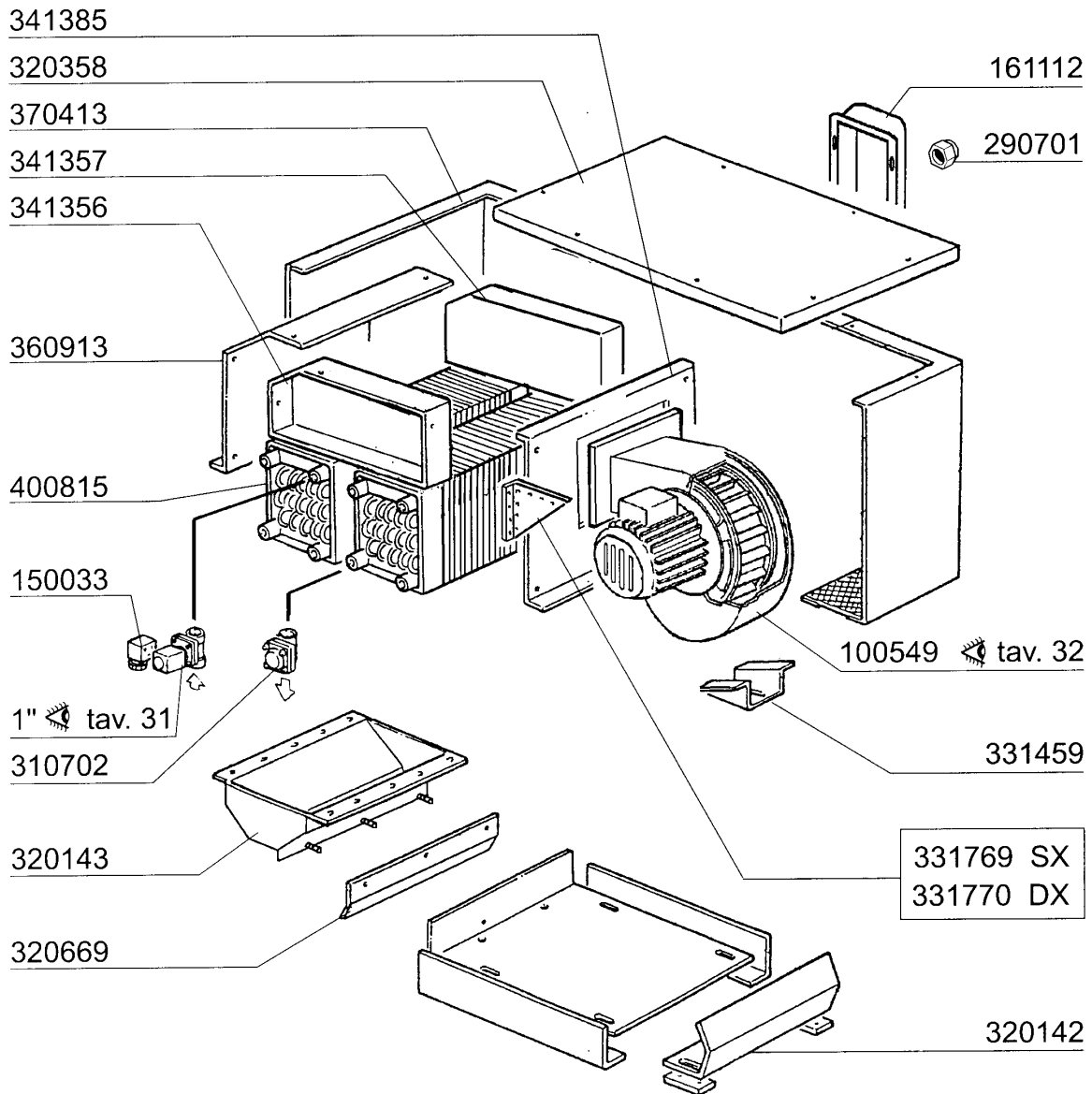

11 - 1999 | S.AG.

13 - Steam Blower Dryer

CODE	DESCRIPTION
100549	DRYER VENTILATOR 3HP NG - NEXL
150033	CONNEC.F.SOLEN.VALVE 182.09.N
161112	BACK COVER CHANNEL 300 S N
290701	HEXAGON BLIND NUTS GM H12
310702	STEAM TRAP 1/2" MK 25/3
320142	DEFLECTOR F. DRYER
320143	DEFLECTOR F. DRYER 1000MM
320358	TOP FOR DRYER 1000MM
320669	FIXING PLATE
331459	BRACKET FOR DRYING VENTILATOR
331769	ZIEHL FAN SUPPORT
331770	ZIEHL FAN SUPPORT
341356	RIGHT PANEL
341357	LEFT PANEL
341385	DRYER FAN SUPPORT FOR NE MACHI
360913	BACK PANEL 1000MM NE XL
370413	DRYING MODULE
400815	BATTERY FOR DRYING (9-12KW) SE

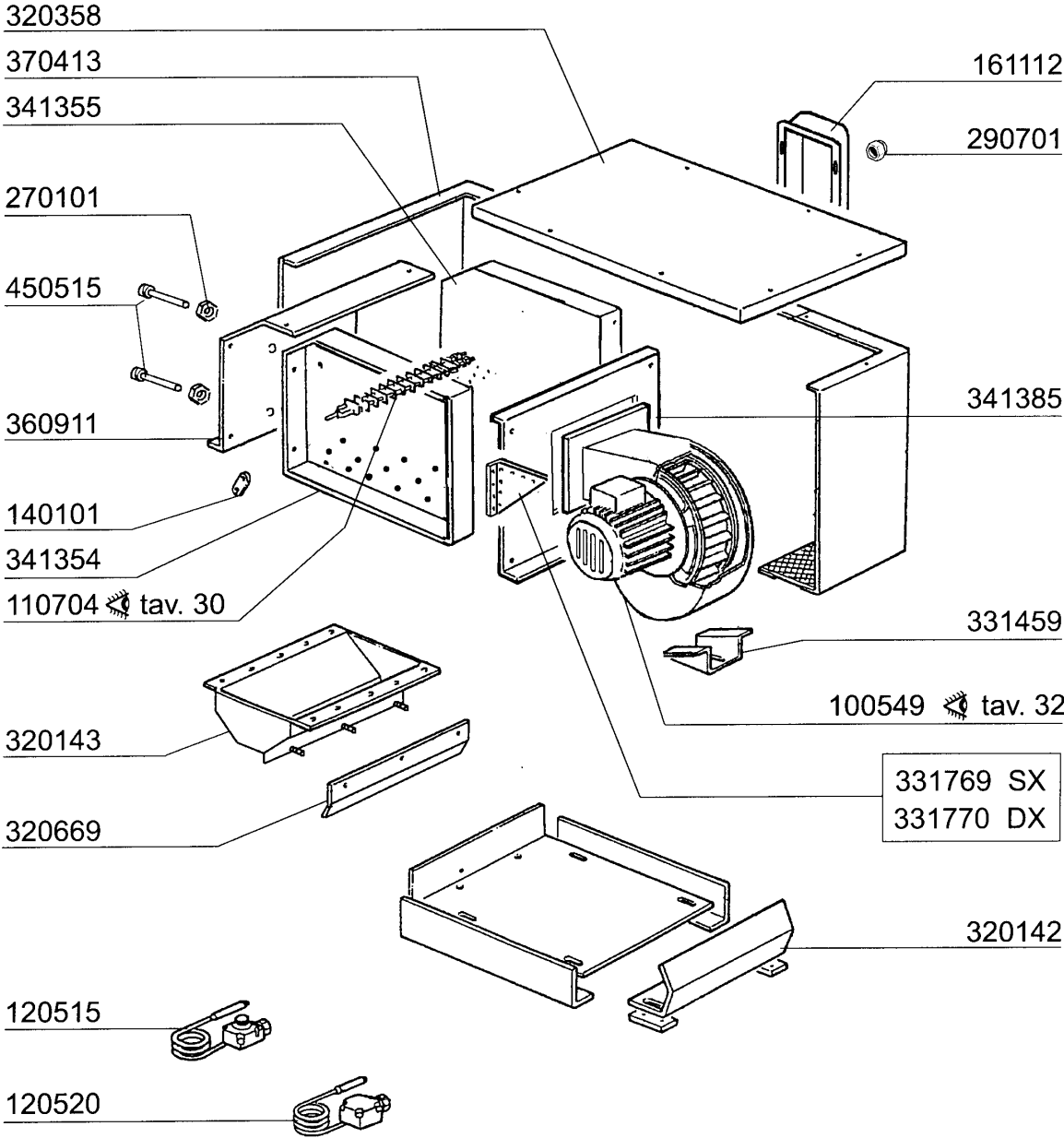

11 - 1999 S. AG.

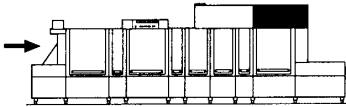

14 - Blower Dryer - electric version

CODE	DESCRIPTION
100549	DRYER VENTILATOR 3HP NG - NEXL
110704	HEAT.ELEMENT/DRYING 1000W 220V
120515	THERMOSTAT 0-90°C
120520	SECURITY THERMOSTAT 110-130°C
140101	BRASS CONNECT. PLATE HEAT.ELEM
161112	BACK COVER CHANNEL 300 S N
270101	HEXAGON LOCK NUT 1/2"
290701	HEXAGON BLIND NUTS GM H12
320142	DEFLECTOR F. DRYER
320143	DEFLECTOR F. DRYER 1000MM
320358	TOP FOR DRYER 1000MM
320669	FIXING PLATE
331459	BRACKET FOR DRYING VENTILATOR
331769	ZIEHL FAN SUPPORT
331770	ZIEHL FAN SUPPORT
341354	RIGHT SUPPORT FOR DRYER 18KW 1
341355	LEFT SUPPORT FOR DRYER 18KW 10
341385	DRYER FAN SUPPORT FOR NE MACHI
360911	PANEL
370413	DRYING MODULE
450515	STAINL.ST.SHIELD FOR 1 THERMOS

15 - Heat recovery unit

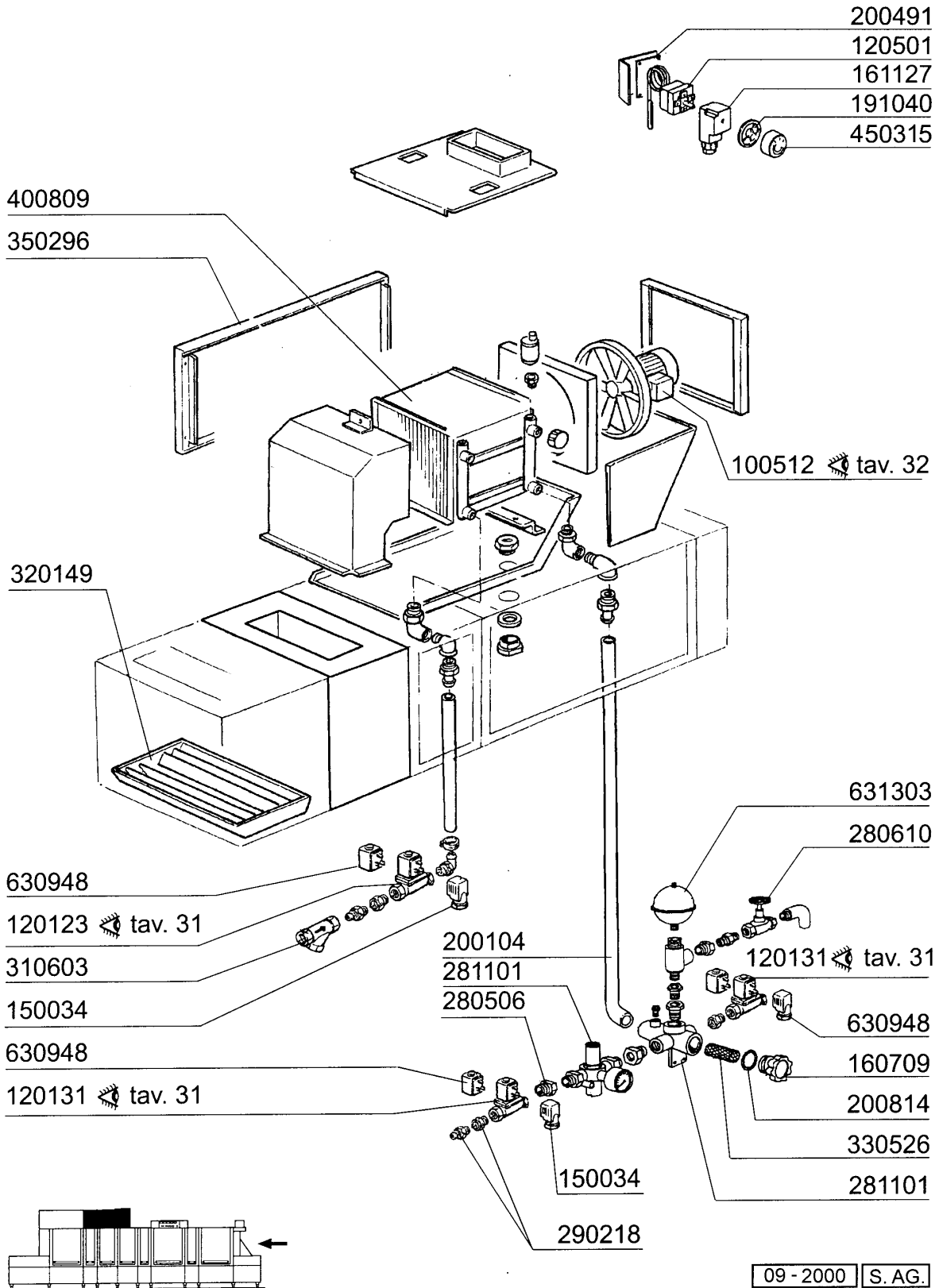

15 - Heat recovery unit

CODE	DESCRIPTION
100512	FAN HP 0,75 400EVH/4/27
120123	SOLENOID VALVE L180B12 1" V.24
120131	SOLEN. L182Q31-ZB10A 1/2"24V
120501	THERMOSTAT 30/90°C
150034	CONNEC.F.SOLEN.VALVE 122.09.N
160709	KNOB OF MANIFOLD F. SOLEN. VAL
161127	BOX FOR THERMOSTAT
191040	FRAME F.THERMOSTAT KNOB
200104	DISCHARGE HOSE 20X30
200491	BACK GASKET OF THERMOSTAT BOX
200814	O-RING 34,52X41,58X3,53
280506	CONNECTION 3/4"
280610	VALVE FOR HEAT RECOVERY UNIT
281101	3/4" ADJ VALVE C/W GAUGE
290218	NIPPLE 12X1/2"
310603	STRAINERS JU 1" MOD.45
320149	CONTAINER FOR HRU
330526	FILTERS 22X28 SOLENOID V.MANIF
350296	PANEL
400809	CONDENSER BATTERY ENERGY REC.
450315	KNOB F. THERMOSTAT 90°
630948	COIL Z610A 24V 50/60-L180V01
631303	HYDRAULIC AIR VESSEL FOR HEAT

☞ tav. 30

120636 (600 VA)
120613 (500 VA)
120635 (400 VA)

130265

150710 (10,3 x 38)
150711 (14 x 51)
150712 (22 x 58)

121022 (32 A)
121023 (40 A)
121024 (50 A)
121025 (63 A)

130911

☞ tav. 30

☞ tav. 30

120445

130620

130605

630977

130925

631214

120741 (80 A)
120742 (125 A)

161112

290701

120736

180129

190144

440817

450323

130264

121205

461078

120925

120910

121204

11 - 1999 S. AG. 01

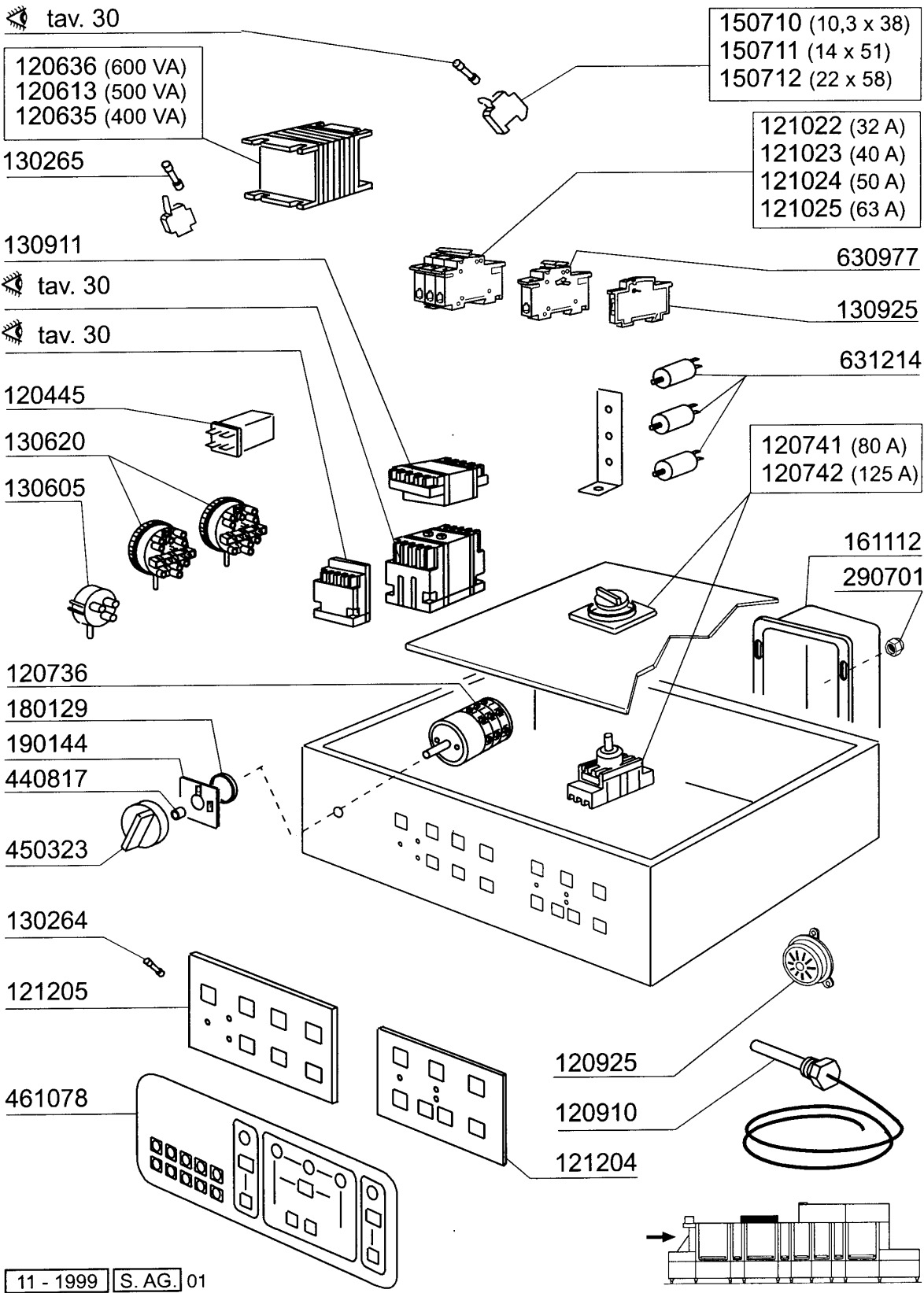

16 - Control Box

CODE	DESCRIPTION
120445	AUXILIARY RELAY S.B2/3 24V
120613	TRANSFORMER 500VA 220-240-380-
120635	TRANSFORMER 400VA220-240-380-4
120636	TRANSFORMER 600VA220-240-380-4
120736	4 POLE MAIN SWITCH 25A 500V
120741	MAIN SWITCH 80A
120742	MAIN SWITCH 125A (120745)
120910	ELECTRONIC TOUCH PAD CONTROLS
120925	ACUSTIC SIGNAL
121022	CIRCUIT BREAKER 32A
121023	CIRCUIT BREAKER 40A
121024	CIRCUIT BREAKER 50A
121025	CIRCUIT BREAKER 63A
121204	ELECTRONIC PANEL THERMOREG.7+1
121205	"ELECTRONIC 2" PANEL
130264	FUSE 5X20 1A
130265	FUSE 5X20 1,6A
130605	PRESSURE SWITCH 50-30 1 LEVEL
130620	PRESSURE SWITCH 3 LEVEL 50-30/
130911	CONTACT LA1 D40 A65
130925	CONTACT FOR CIRCUIT BREAKER
150710	FUSE CARRIER 10,3X38 ART.21401
150711	FUSE CARRIER 14X51 ART.21501
150712	FUSE CARRIER 22X58 ART.21601
161112	BACK COVER CHANNEL 300 S N
180129	NUT FOR MAIN SWITCH SUPPORT
190144	MAIN SWITCH HOLDER
290701	HEXAGON BLIND NUTS GM H12
440817	SNAP RING LSCB/1853/17/00
450323	KNOB FOR BC-BR-C95-C155
461078	PLATE "ELECTRONIC 2"
630977	COIL FOR CIRCUIT BREAKER 24V
631214	ANTI-NOISE FILTER 4011135007 3

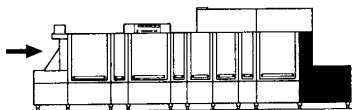
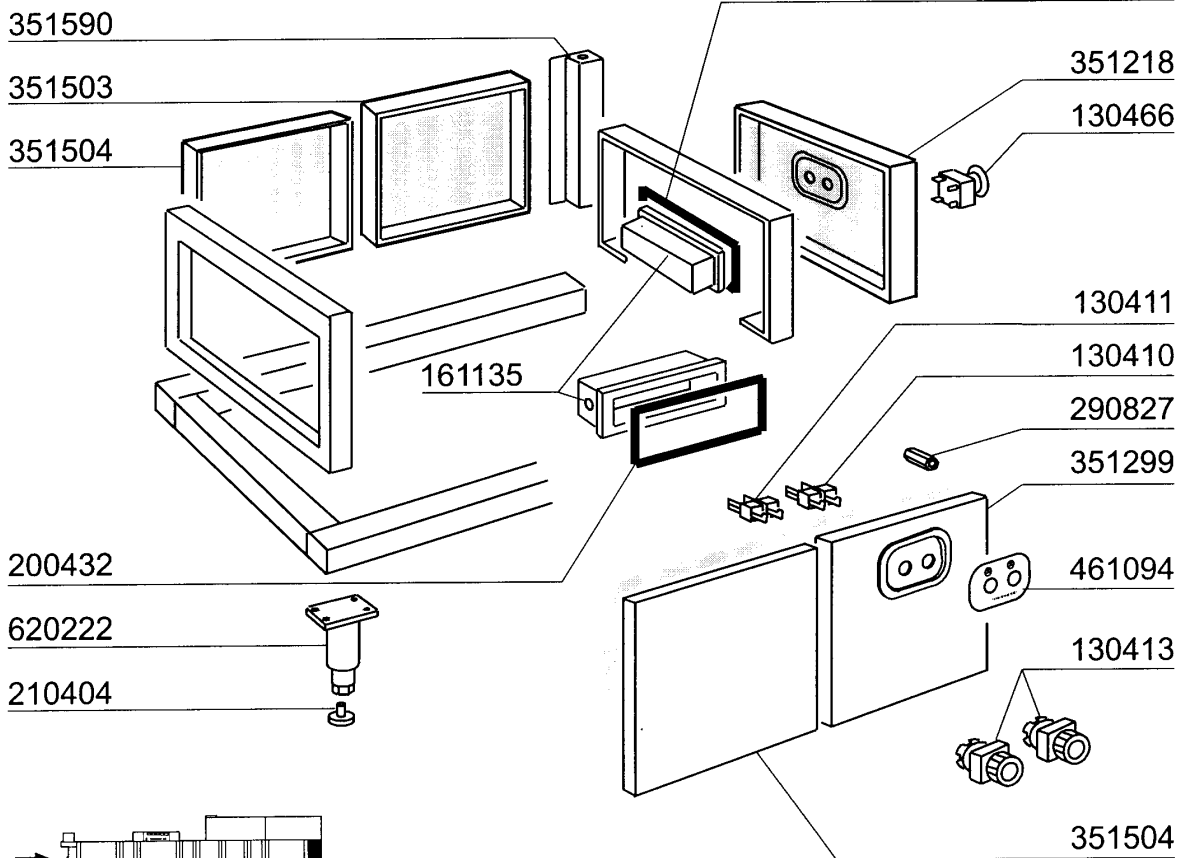
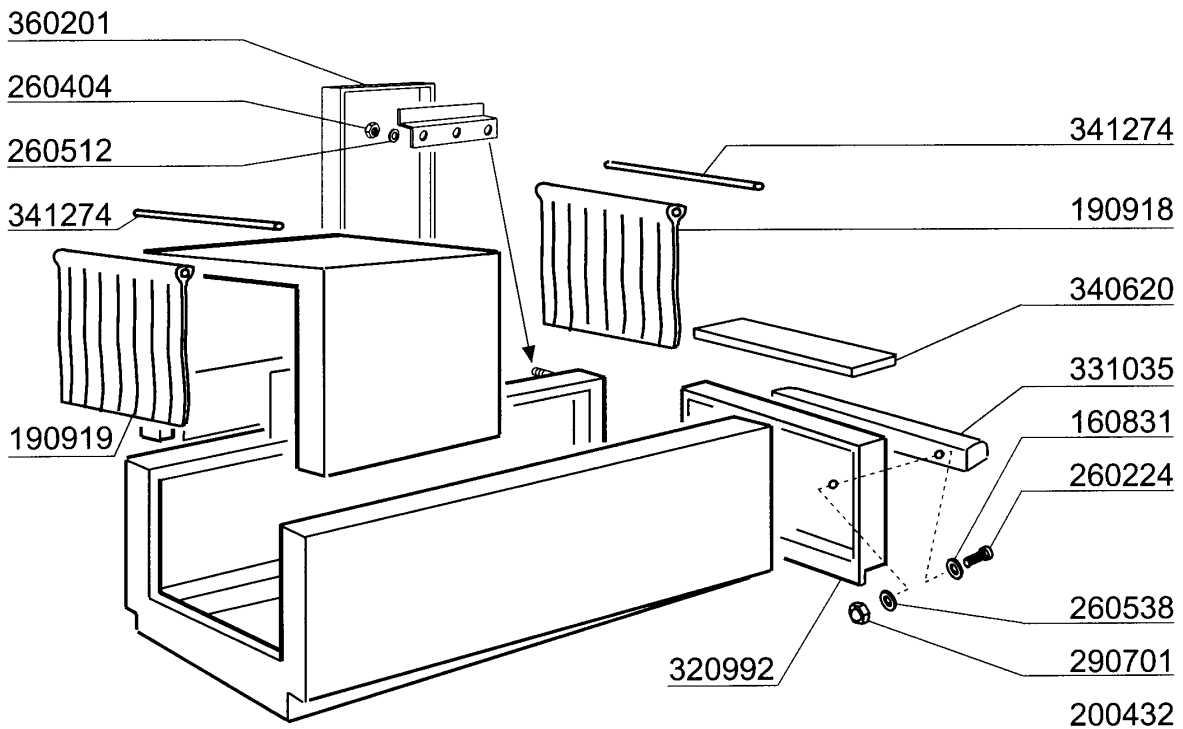

17 - Exit table

CODE	DESCRIPTION
130410	STOP CONTACT F40 CN RED
130411	START CONTACT YELLOW
130413	GREEN PUSH BUTTON
130466	EMERGENCY SWITCH
160831	WASHER F2 17X6X3
161135	PROTECTION FOR PUSH BUTTON NE
190918	CURTAIN IN/OUT NG-910X680
190919	MIDDLE CURTAIN NG-910X680
200432	SPONGY RUBBER ADHESIV 8X4 NEOP
210404	BLACK RUBBER FOOT S90 NE SE
260224	TB-SCREW 6X15 B23-10-11-12
260404	STAINLESS STEEL NUTS D6 UNI 55
260512	ST/ST GROWER WASHER D6
260538	WASHER 18X6X1,5 ST/ST
290701	HEXAGON BLIND NUTS GM H12
290827	SPACER NG-LVP1001
320992	DOOR
331035	HANDLE NE/G125L
340620	EXIT TABLE COVER
341274	PIN
351218	PANEL
351299	PANEL
351503	BACK PANEL
351504	PANEL 600 NE
351590	PANEL
360201	COVER
461094	CONTROL PANEL
620222	COMPLETE ALUMINIUM LEGS

- 410307 - Z 32
- 410309 - Z 38
- 410303 - Z 50
- 410304 - Z 60

- 451116
- 410401
- 440402
- 200802
- 180201

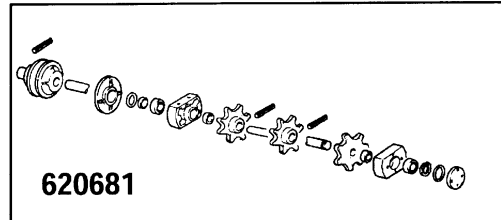

410801

410902

410903

- 410229 - Z 14 ø 30
- 410220 - Z 16 ø 30
- 410241 - Z 17 ø 30
- 410221 - Z 18 ø 30

- 410110
- 510250
- 440402
- 510229
- 341269
- 510229

451116

440402

510249

410109

440802

200802

180202

100236 tav. 32

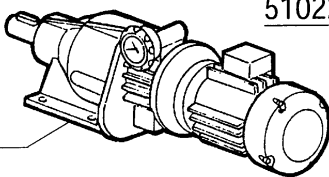

440402

510251

410109

440802

200802

180202

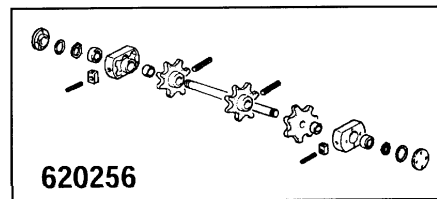

451116

440402

510251

410109

440802

180202

200802

510229

341268

510229

330201

381101

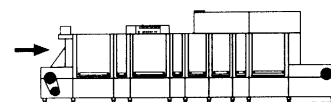

11 - 1999 S.AG. 01

18 - Drive unit

CODE	DESCRIPTION
100236	VARIABLE DRIVE MOTOR 220/380
180201	DRILLED FLANGE 85 /DRIVE
180202	BLIND FLANGE D.85 (DRIVE) N
200802	OR GASKET 3,53X44,05X51,11
330201	ROD FOR BELT ADJUSTING "N"
341268	PIN FOR CONVEYOR
341269	PIN
381101	PLATE
410109	BEARINGS 17X40X12 6203
410110	BEARINGS 20X42X12 6004
410220	TURNED PINION Z16-1/2"-D.30
410221	PINION Z18 D.30
410229	TURNED PINION Z14-1/2"-D.30
410241	TURNED PINION Z17-1/2"-D.30
410303	CROWN DISCS 50T 1/2" PITCH
410304	CROWN DISCS 60T 1/2"PITCH
410307	CROWN DISCS 1/2" PITCH
410309	CROWN DISCS 38T 1/2PITCH
410401	NICKEL-PLATED TORQUE LIMITER L
410801	DRIVE CHAIN 1/2" N-S
410902	FALSE CHAIN LINK 1/2"
410903	CHAIN JOINT 1/2"
440402	SEAL RING 20X30X5
440802	SEAL RING D.17 EXT.
451116	ELASTIC PIN 6X40
510229	DRIVE SHAFT SPROCKET
510249	NICKEL-PLATED BEARING F. SHAFT
510250	BEARING OF SHAFT N
510251	BEARING OF IDLE SHAFT N
620256	IDLE SHAFT FOR NG-BELT
620681	CONVEYOR SPINDLE

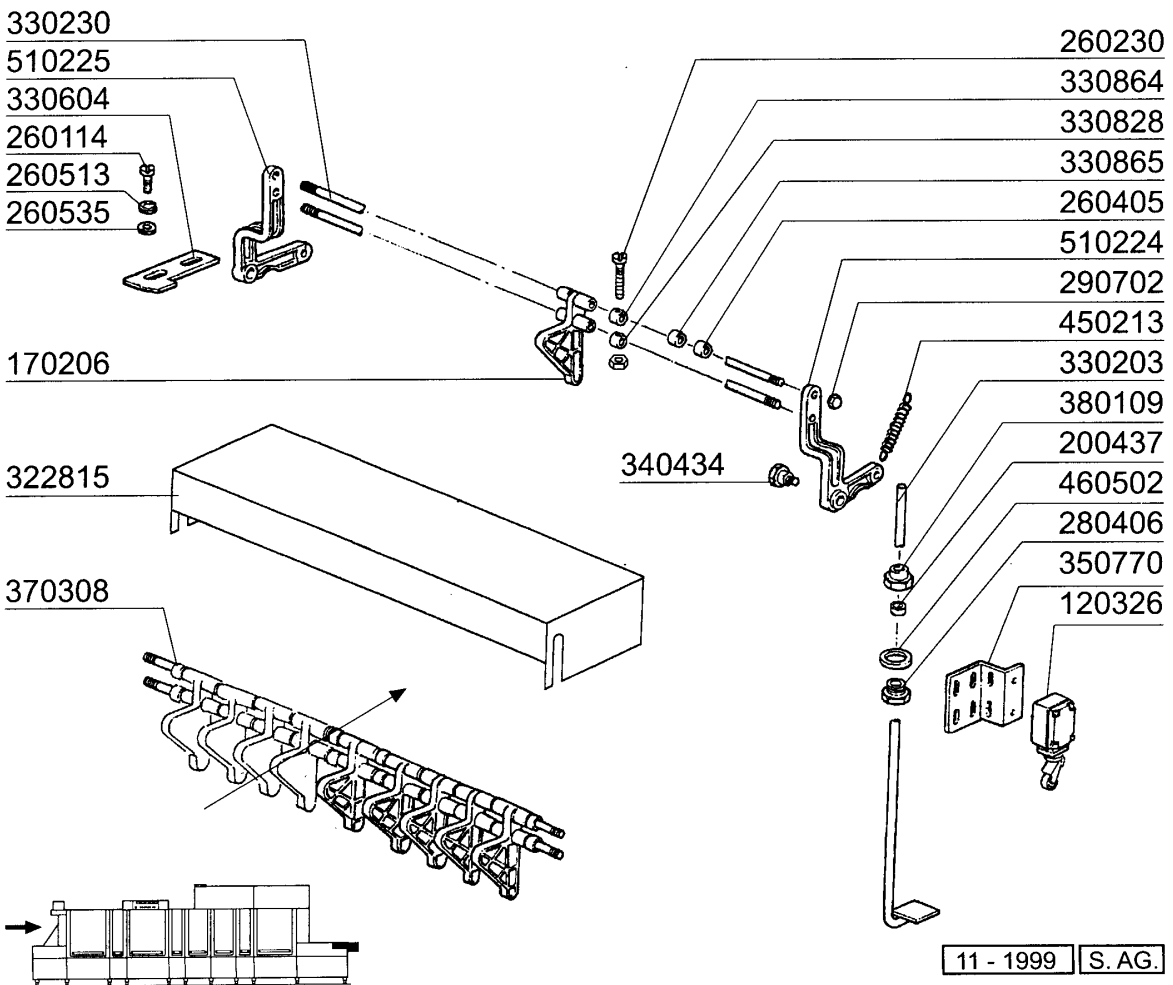
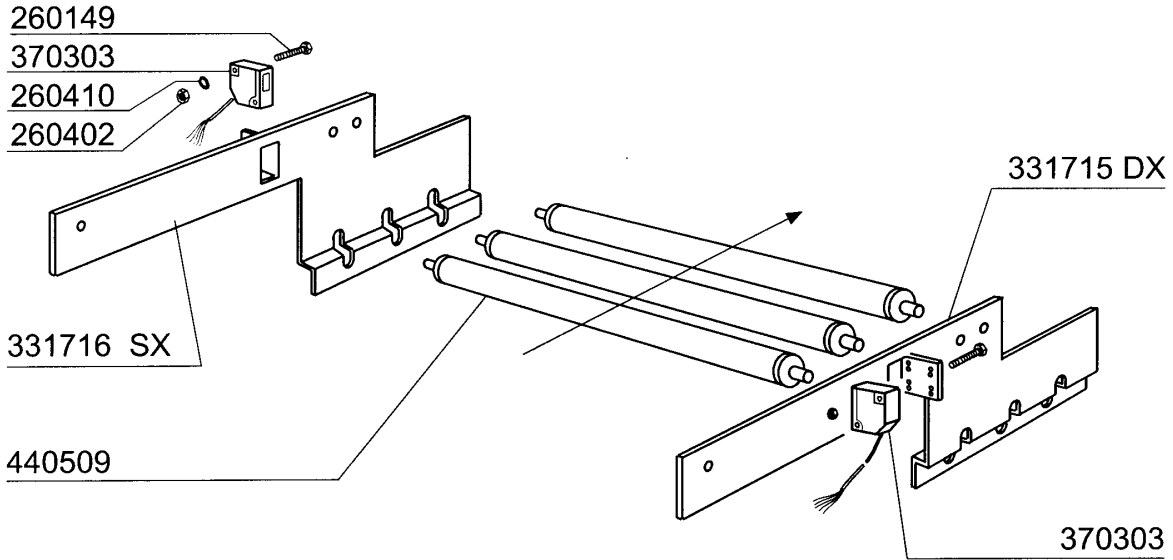

19 - End Run Switch

CODE	DESCRIPTION
120326	MICRO SWITCH FD 102
170206	PEG N IN MOPL / END RUN ARM
200437	GASKET FOR END RUN ARM N GACO
260114	SCREW TE 8X25
260149	SCREW TE 4X25
260230	SCREW TCP 4X40
260402	STAINLESS STEEL NUT D4 UNI 55
260405	NUT D.8
260410	NUT
260513	GROWER WASHER D8
260535	STAINL.ST WASHER 24X8,5X2
280406	NICKEL-PLATED BUSH F.KNOCK OFF
290702	HEXAGON BLIND NUTS 8M H15
322815	COVER
330203	ROD FOR MICRO CONTROL "N"
330230	TIE ROD F. END RUN ARM NG
330604	RETAINER F.KNOCK OFF ARM N
330828	STIFF.SPACERS FOR END RUN ARM
330864	STIFF.SPACERS FOR END RUN ARM
330865	BUSH
331715	BRACKET
331716	BRACKET
340434	CRANK HEAD PIN
350770	BRACKET F.MICRO /NOCK OFF GATE
370303	PHOTOCELL
370308	CONVEYOR END RUN NG
380109	THREADED BUSH 1/2" KNOCK OFF G
440509	S/S DISCHARGE ROLLER FOR NG
450213	STAINL.ST SPRING D.10 LIMIT SW
460502	GASKET 30X21X2
510224	RIGHT SUPPORT LEVER F.END RUN
510225	LEFT SUPPORT LEVER F.END RUN

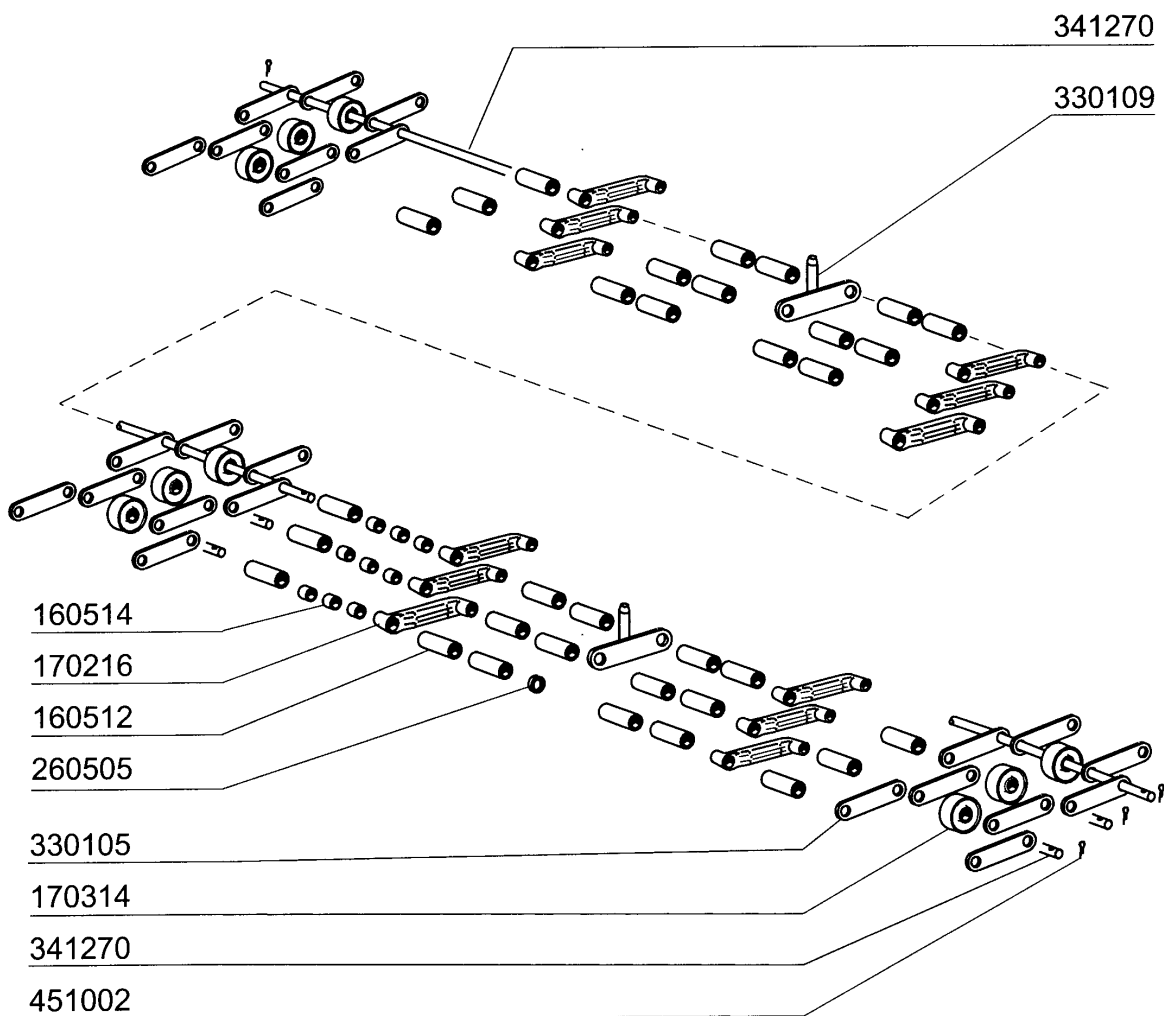
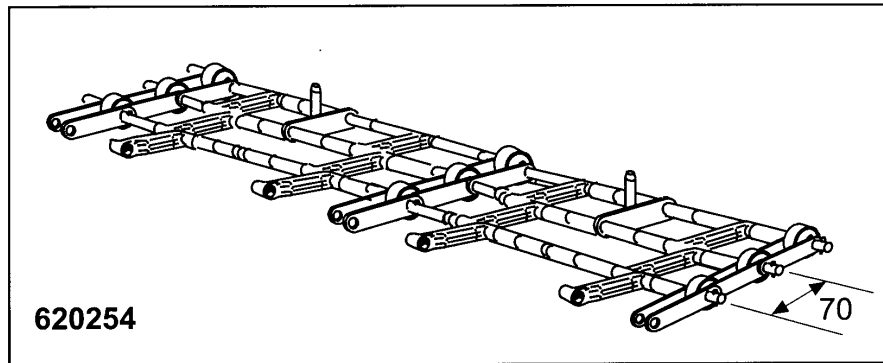

11 - 1999 S. AG.

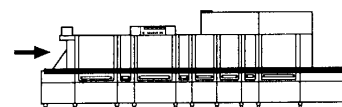

20 - Flat Conveyor

CODE	DESCRIPTION
160512	SPACER 35,5
160514	SPACER 7,9 108378 MOP
170216	SPACER FOR BELT 60MM
170314	GRAY BELTWHEEL N
260505	STAINL.STEEL FLAT WASHER D8
330105	LINKS 2 FOR BELT NST.88
330109	S/S FINGER FOR NE FLAT CONVEYO
341270	PIN
451002	COTTER PIN STAINL.ST. D2X12
620254	COMPL.SHAFT NG BELT (CENTRAL G

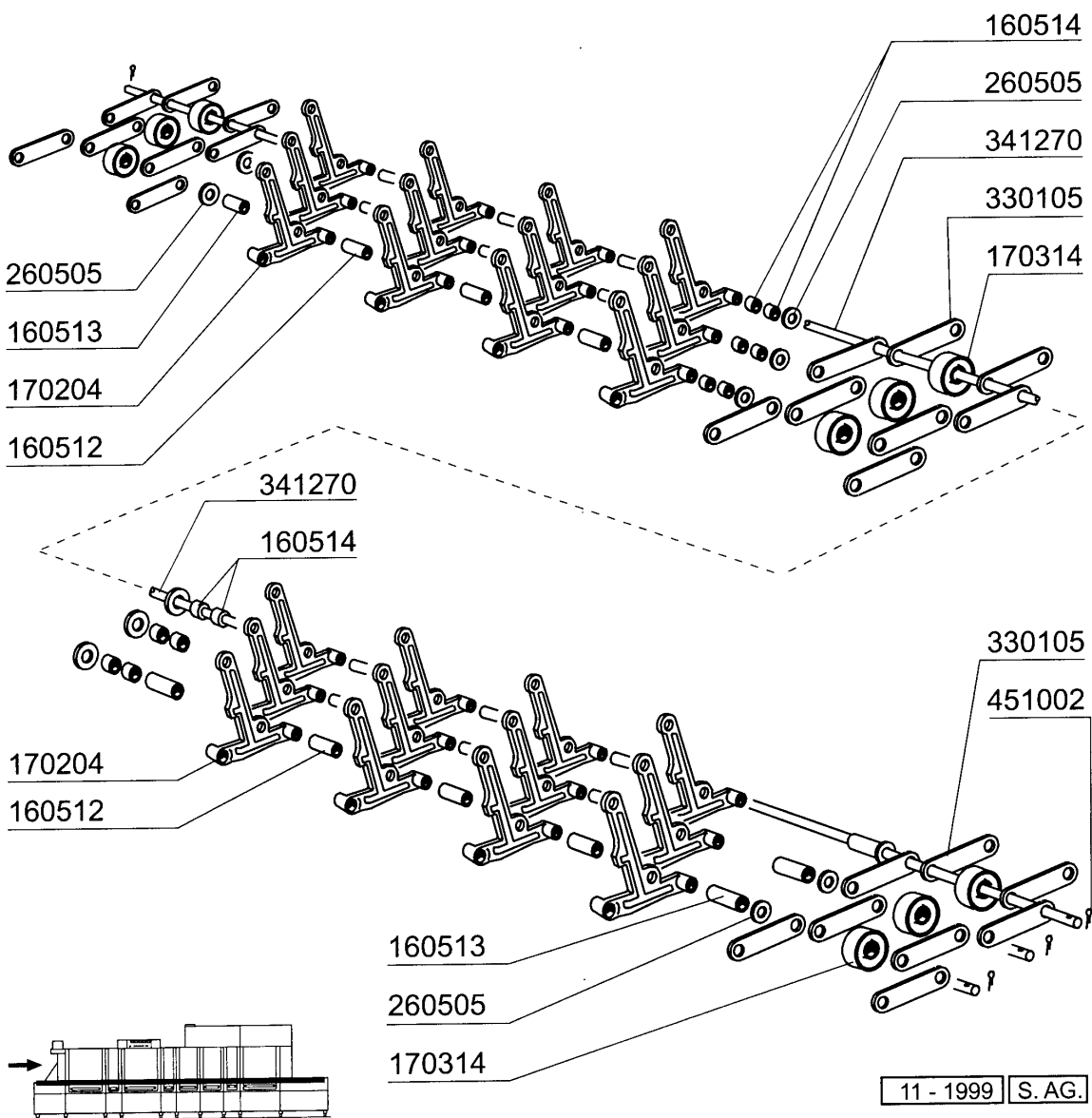
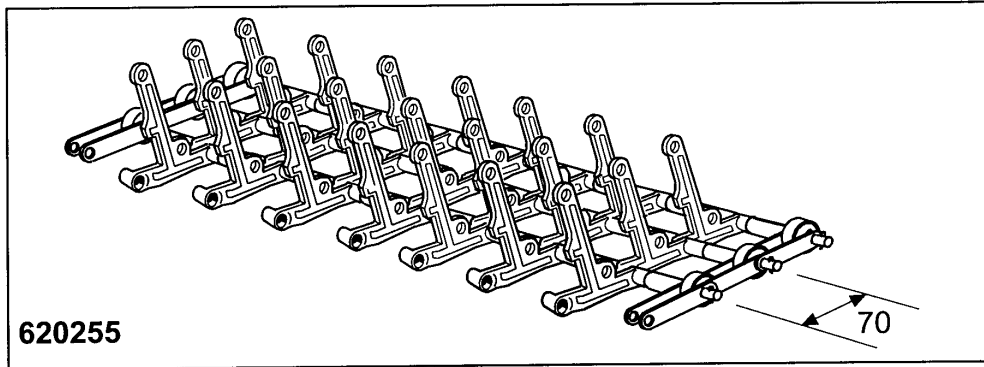

CODE	DESCRIPTION
160512	SPACER 35,5
160513	SPACER 27,8
160514	SPACER 7,9 108378 MOP
170204	GRAY FINGER FOR BELT N
170314	GRAY BELTWHEEL N
260505	STAINL.STEEL FLAT WASHER D8
330105	LINKS 2 FOR BELT NST.88
341270	PIN
451002	COTTER PIN STAINL.ST. D2X12
620255	BELT

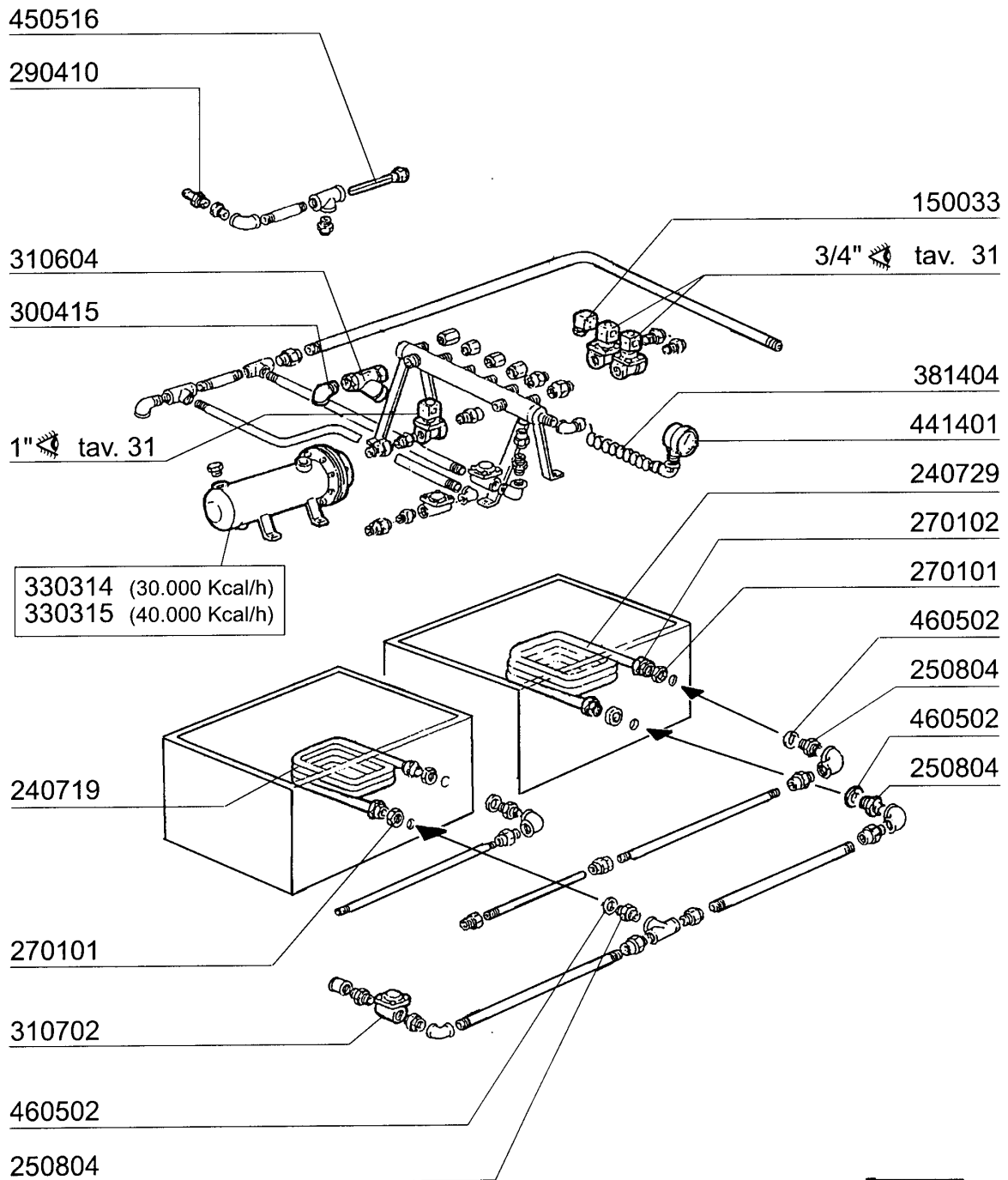



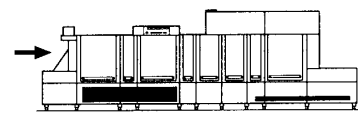

11 - 1999 S. AG.



22 - Steam Version

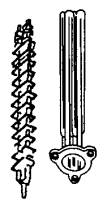

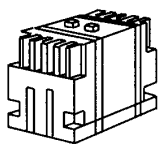
CODE	DESCRIPTION
150033	CONNEC.F.SOLEN.VALVE 182.09.N
240719	S/S STEAM COIL 18000 KCAL NE/N
240729	WATER COIL
250804	NIPPLES FOR STEAM COIL
270101	HEXAGON LOCK NUT 1/2"
270102	LOCK NUT 3/4"
290410	NIPPLE 1/2"
300415	ELL 2" MF
310604	STRAINERS JU 2" MOD.45
310702	STEAM TRAP 1/2" MK 25/3
330314	STEAM BOILER 30000 KCAL/H
330315	STEAM BOILER 40000KCAL/H
381404	HOSE STEAM GAUGE
441401	PRESSURE GAUGE 60 SCALO-4CR1/4
450516	THERMOSTAT SHIELD FOR 2 TERMOS
460502	GASKET 30X21X2

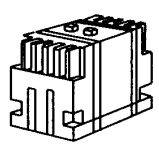
23 - Electrical parts for heating elements

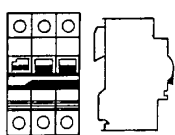
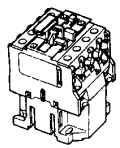
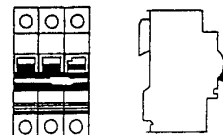
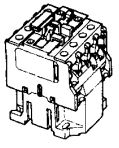
220 / 240 V					380 / 415 V				
									
KW	A	FUSIBILI FUSIBLE FUZE SCHMELZSICHERUNG FUSIBLE	A	TELERUTTORE CONTACTEUR CONTACTOR SCHALTSCHÜTZ CONTACTOR	A	FUSIBILI FUSIBLE FUZE SCHMELZSICHERUNG FUSIBLE	A	TELERUTTORE CONTACTEUR CONTACTOR SCHALTSCHÜTZ CONTACTOR	
6,00	20	130248	12	120429	12	130246	9	120428	
16,00	50	130257	40	120431	32	130237	25	120437	
18,00	63	130239	63	120433	32	130237	40	120431	

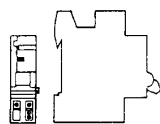
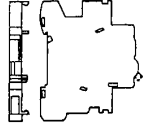
220/240 V					380/415 V				
									
KW	A	MAGNETOTERMICO RESISTENZA MAGNETO-TERMIQUE RESISTANCE TERMO-MAGNETIC SWITCH FOR HEATER TERMO-MAGNETISCHER SCHALTER F.EIZKÖRPER MAGNETO-TERMICO RESISTENCIA	A	TELERUTTORE CONTACTEUR CONTACTOR SCHALTSCHÜTZ CONTACTOR	A	MAGNETOTERMICO RESISTENZA MAGNETO-TERMIQUE RESISTANCE TERMO-MAGNETIC SWITCH FOR HEATER TERMO-MAGNETISCHER SCHALTER F.EIZKÖRPER MAGNETO-TERMICO RESISTENCIA	A	TELERUTTORE CONTACTEUR CONTACTOR SCHALTSCHÜTZ CONTACTOR	
16	50	121024	55 40	120431	25	121021	32 25	120437	
18	63	121025	70 63	120433	25	121021	32 25	120437	
21	63	121025	70 63	120433	32	121022	55 40	120431	
24	80	121026	70 63	120433	32	121022	55 40	120431	
30	80	121026	100 80	120441	40	121023	55 40	120431	

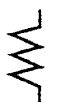
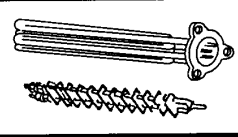
	BOBINA DI SGANCIO V. 24 PER BOILER BOBINE DÉCROCHAGE V. 24 POUR SURCHAUFFEUR DISCONNECTING COIL V. 24 FOR BOILER AUSLÖSESPÜLE V. 24 FÜR BOILER BOBINA DESEMBRAGUE V. 24 POR BOILER		CONTATTO PER BOBINA DI SGANCIO CONTACT BOBINE DÉCROCHAGE CONTACT FOR DISCONNECTING COIL KONTACT FÜR AUSLÖSESPÜLE CONTACTO POR BOBINA DE DESEMBRAGUE
Cod. 630977		Cod. 130925	

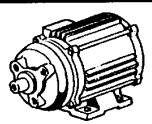
			220/380 V	240/415 V	
			6 KW	110349	110383
			8 KW	110343	110365
			9 KW	110362	110343
			10 KW	110388	110381
					

11 - 1999 S.A.G.

23 - Electrical parts for heatings elements

CODE	DESCRIPTION
110343	HEAT.ELEM. 8000W 220/380V
110349	HEAT.ELEMENT 6000W 230/400V
110362	HEAT.ELEMENT 9000W 220/380V
110365	HEAT.ELEM. 9000W 255/440V-8KW
110381	HEAT.ELEMENT 12500W 254/440V
110383	HEAT.ELEMENT 6KW 240/415
110388	HEAT.ELEMENT 10000W 230/400V
120428	CONTACTOR 9A 24V 50HZ
120429	CONTACTOR 12A 24V 50HZ
120431	CONTACTOR 40A 24V 50HZ
120433	CONTACTOR 63A 24V 50HZ
120437	CONTACTOR 25A 24V 50HZ
120441	CONTACTOR 80AMP 24V 50HZ
121021	CIRCUIT BREAKER 25A
121022	CIRCUIT BREAKER 32A
121023	CIRCUIT BREAKER 40A
121024	CIRCUIT BREAKER 50A
121025	CIRCUIT BREAKER 63A
121026	MAGN.SWITCH 80A
130237	FUSE 14X51 32A GL14332
130239	FUSE 22X58 63A GF15363
130246	FUSE 10.3X38 12A GF13312
130248	FUSE 20A-10,3X38 13320 G.F.
130257	FUSE 50A 14X51 GF14350
130925	CONTACT FOR CIRCUIT BREAKER
630977	COIL FOR CIRCUIT BREAKER 24V

ELETTROVALVOLA VAPORE - ELECTROVANNE VAPEUR - STEAM SOLENOID VALVE - DAMPF-VENTIL
ELECTROVALVULA VAPOR

150033

120166 (1")
120165 (3/4")

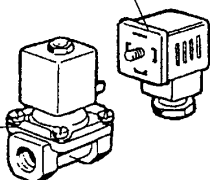

630976 (1")
630972 (3/4")



630629 (1")
630628 (3/4")



0 ÷ 2 bar

150033

120163 (1")
120162 (3/4")

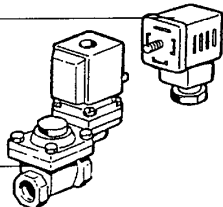

630972 (1")
630973 (3/4")

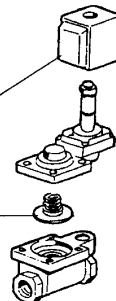

630626 (1")
630625 (3/4")

0,5 ÷ 2,5 bar

ELETTROVALVOLA ACQUA - ELECTROVANNE EAU - WATER SOLENOID VALVE - WASSER-VENTIL
ELECTROVALVULA AGUA

150034

120131 (1/2")

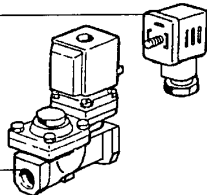

630948

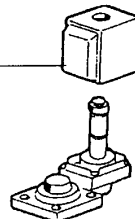

631631
L180Q31

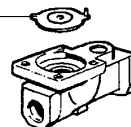

150034

120123 (1")

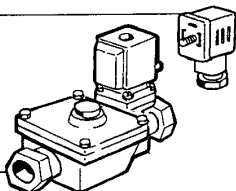

630948



630609
L180Q17



PER RECUPERATORE DI CALORE - POUR ECONOMISEUR D' ENERGIE
FÜR WÄRMERÜCKGEWINNUNG - FOR HEAT RECOVERY UNIT - PARA RECUPERADOR DE CALOR

24 - Solenoid Valve

CODE	DESCRIPTION
120123	SOLENOID VALVE L180B12 1" V.24
120131	SOLEN. L182Q31-ZB10A 1/2"24V
120162	SOLENOID VALVE L145R1Z734A 3/4
120163	SOLEN.VAL.ST.L145R1Z234A 1"24V
120165	SOLEN.VALVE ST.24V50HZ 3/4"
120166	STEAM SOLEN.VALVE 1" 24V-50
150033	CONNEC.F.SOLEN.VALVE 182.09.N
150034	CONNEC.F.SOLEN.VALVE 122.09.N
630609	DIAPHRAGM L180Q17-3/4
630625	KIT F.SOLEN.VALVE
630626	KIT FOR SOLENOID VALVE 145 1"
630628	KIT F.SOLEN.V.L153D1 3/4"
630629	KIT SOLENOID VALVE 1" STEAM L1
630948	COIL Z610A 24V 50/60-L180V01
630972	COIL Z534A/V.24-L145A-3/4
630973	COIL Z614A/V.24-L145-3/4 A
630976	COIL Z114A/V24/50HZ L153-1"
631631	VOLUTE ECEB HP1

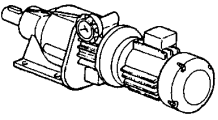
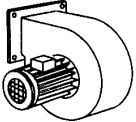
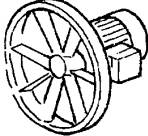
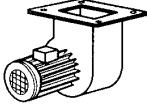
	KW	220/240 V 3 ~						380/415 V 3 ~					
		TELERUTTORE CONTACTEUR CONTACTOR SCHALTSCHÜTZ CONTACTOR	A	TERMICA TERMIQUE OVERLOAD RELAY TERMOAUSLÖSER TERMICO	A	FUSIBILI FUSIBLE FUZE SCHMELZSICHERUNG FUSIBLE	A	TELERUTTORE CONTACTEUR CONTACTOR SCHALTSCHÜTZ CONTACTOR	A	TERMICA TERMIQUE OVERLOAD RELAY TERMOAUSLÖSER TERMICO	A	FUSIBILI FUSIBLE FUZE SCHMELZSICHERUNG FUSIBLE	A
	0,3	120428	9	120822	1,6-2,5	130230	4	120428	9	120821	1-1,6	130260	2
	2,5	120428	9	120825	5,5-8	130233	10	120428	9	120824	4-6	130232	8
	0,55	120428	9	120823	2,5-4	130230	4	120428	9	120822	1,6-2,5	130230	4
	0,09	120428	9	—	—	130259	1	120428	9	—	—	130259	1

CODE	DESCRIPTION
120428	CONTACTOR 9A 24V 50HZ
120821	OVERLOAD RELAY 1/1,6A
120822	OVERLOAD RELAY 1,6-2,5A
120823	OVERLOAD RELAY 2.5/4 A
120824	OVERLOAD RELAY 4/6 A
120825	OVERLOAD RELAY 5,5/8 A
130230	FUSE 10,3X38 4A AM13004
130232	FUSE 10.3X38 8A AM13008
130233	FUSE 10,3X38 10A AM13010
130259	FUSE 10,3X38 1A AM 13095
130260	FUSE 10,3X38 2A AM 13001

630518
 631661 Ø 122
 200848
 630128

100698 220/240 - 380/415 50 Hz
 100705 220/240 - 380/415 60 Hz
 100699 255/440 60 Hz

HP 0,75 / Kw 0,55 **(CEA 120/2)**

630529

631661 50 Hz Ø 122
 631696 60 Hz

200848
 630128

100789 220/240 - 380/415 50 Hz
 100792 220/240 - 380/415 60 Hz
 100793 255/440 60 Hz

HP 0,75 / Kw 0,55 **(CEA 120/2/A)**

630520

631693 50 Hz Ø 116
 631694 60 Hz Ø 90

200948
 460526
 460525

100697 220/240 - 380/415 50 Hz
 100709 220/240 - 380/415 60 Hz

HP 4 / Kw 3 **(SHE 50)**

CODE	DESCRIPTION
100697	PUMP HP 4 230/400/50 SHE 50
100698	PUMP HP 0,75-CEA120 (100789)
100699	PUMP 1HP 255/440 60HZ CE1206/1
100705	PUMP HP0,75 220-380 60H(100792)
100709	PUMP HP 4 220/380/415V 60HZ
100789	PUMP HP 0,75 220/415V
100792	PUMP HP 0,75 220/415
100793	PUMP HP 0,75
200848	O-RING FOR PUMP 0,75 HP CEA 12
200948	OR GASKET
460525	GASKET INLET ELBOW WASH PUMP
460526	GASKET DELIVERY ELBOW WASH P.
630128	PUMP VOLUTE 0,75HP CEA120/2
630518	PUMP SEAL HP0,75 CE120
630520	PUMP SEAL HP4-HTE50E
630529	SEAL FOR PUMP HP0,75 CEA120/2A
631661	IMPELLER PUMP 0,75HP LOW.CE120
631693	IMPELLER FOR PUMP 100697
631694	IMPELLER
631696	IMPELLER 60HZ FOR PUMP 100792